

STAFF REPORT

DATE: April 16, 2026
TO: Zoning Board of Appeals
FROM: Ray Heitner - Planner
RE: Petition Number: 2026-04
Applicant: David Mikel – SES Branding
Status of Applicant: Agent of the property owner
Location: 16329 S. Boulevard Place
Request: A series of Variations on signage (COUNCIL DISTRICT #1)

Purpose

The applicant is requesting the following variations to allow signage as shown on the attached elevations for a new Longhorn Steakhouse restaurant at 16329 S. Boulevard Place:

- Variation to allow two wall signs on the north side of the building
- Variation to allow two wall signs on the west side of the building

The Zoning Board of Appeals makes the final decision on these variation requests.

Site Specific Information

The subject property is a 1.5-acre lot within the Boulevard Place Planned Unit Development (PUD) located northwest of the Plainfield Road and Interstate 55 interchange. The proposed restaurant is under construction on Lot 7 of the Boulevard Unit 4 subdivision within the PUD.

When the Boulevard Place PUD was last amended in 2019, the City of Joliet entered into an Intergovernmental Agreement to adopt Design Guidelines that both municipalities would use to establish mandatory development standards for properties within the PUD footprint. The Design Guidelines are intended to supplant each municipality's zoning regulations. The Site Development Standards section within the Design Guidelines regulates signage. Section 3b(v) of the Standards states that only one wall sign per building frontage of the building shall be permitted. The petitioner wishes to install two signs on the north and west sides of the restaurant. Staff views the requested variations as a minor change from the concept and intent of the Boulevard Place Design Guidelines, which allows for the City's discretion to require approval of the requested Variations by the Zoning Board of Appeals.

Both the north and west sides of the building would include an approximately sized, 69-square-foot, internally illuminated, channel letter sign spelling out the restaurant's name. These façades would also include an approximately sized, 20-square-foot, steer logo sign that is a common feature of other Longhorn Steakhouse restaurants. The requested size of all signage is within the allowable square footage.

Surrounding Zoning, Land Use and Character

The subject property is the Boulevard Place PUD and is surrounded by B-3 (General Business) district zoning on the west, north, and east sides. Interstate 55 right-of-way is directly south of the subject property.

Applicable Regulations

- Section 2(f)(g) Planned Development Design Guidelines – Minor Changes
- Section 3b Planned Development Design Guidelines – Wall Signs
- Section 47-19.8 Findings of Facts Supporting a Variation (refer to attachment)

Analysis

Approval of the requested variations would allow the developer to install two signs on the north and west facades of the proposed restaurant building. Section 47-19.8 of the City's Zoning Ordinance details the findings of fact that need confirmation to support a variation request. Staff does not believe a hardship or practical difficulty to allow the proposed signage exists. The property in question can still yield a reasonable return if the variations are not granted and there are no perceived unique circumstances.

However, staff does believe that the variations, if granted, will not alter the essential character of the locality. The requested signage is a common feature on other Longhorn Steakhouses throughout the country. Staff concurs with the applicant's assertion that the proposed signage is architecturally integrated with the building design, utilizes channel letters and halo-illuminated logos that are consistent with other commercial developments in the PUD area, and does not introduce excessive height, animation, or off-premise messaging. The signage as proposed does not introduce visual clutter beyond what is typical for similar properties in the PUD area. For these reasons, staff supports the requested variations to allow additional signage on the north and west facades of the building.

Conditions

None.

ZONING BOARD OF APPEALS
CRITERIA FOR VARIATIONS

Section 47-19.8 of the Zoning Ordinance states:

A variation shall not be granted in any case unless the Board shall find and clearly state in its record of the case that:

	Does the evidence presented sustain this criteria?	Comments
(1) Reasons sustaining the contention that strict enforcement of the Ordinance would involve practical difficulties or impose exceptional hardship were found as follows: (a) _____ (b) _____ (c) _____ (list of reasons)		
(2) Adequate evidence was submitted to establish practical difficulties or particular hardship so that, in the judgment of the Board, a variation is permitted because the evidence sustained the existence of each of the three following conditions: (a) The property in question cannot yield a reasonable return if permitted to be used only under the conditions allowed by the regulations in the particular district or zone. (b) The plight of the owner is due to unique circumstances. (c) The variation, if granted, will not alter the essential character of the locality.		
(3) A public hearing was held on such variation of which at least 15 days and not more than 30 days notice was published in the _____ (name of newspaper) on _____ (date).		



Zoning Board of Appeals Application Packet

Variation

This packet should contain all of the following documents:

- Application;
- Ownership disclosure form;
- Public notice sign posting requirements and sign template

If you have any questions please contact the Planning Division staff.

Joliet Planning Division - 150 West Jefferson Street,
First Floor-South Wing, Joliet, Illinois 60432

Phone Number: (815) 724-4050

Email Address: zoning@joliet.gov

Filing Fees:

The following fees **will be invoiced** once the petition is accepted:

Filing Fee Type	Amount
Variation for a Single-Family Home	\$200.00
Variation for a Mutli-Family Property	\$500.00
Variation for a Non-Residential Property	\$500.00
Additional Variations	\$50.00 each
Sign Deposit Fees (properties that are less than one (1) acre)	\$100.00 (\$50.00 for an English sign & \$50.00 for a Spanish sign)

Notice of Petition Request:

In accordance with Resolution No. 1694 of the City of Joliet, all persons residing within 600 ft. of the property referred to in this application must be notified of the proposed re-zoning. The Planning Division will notify these residents 10 days prior to the meeting of the Zoning Board of Appeals.

Sign Deposits:

At least one sign shall be posted no later than 15 days, but not more than 30 days before, the hearing date. The sign shall contain the time and place of the public hearing and the nature of the request. It shall be placed in a conspicuous location on the property so it may be observed and read from the street. If the property is less than one (1) acre, the sign shall be provided by the City of Joliet Planning Staff upon the applicant's payment of the \$50.00 deposit for each sign. It shall be the applicant's responsibility to post the sign. If the property is larger than one (1) acre, the applicant shall be responsible for creating and erecting the sign. **For properties larger than one (1) acre, please refer to the "Requirements For Posting Land Use Change Informational Signs" sheet in this packet.**

Upon completion of the public hearing, the sign(s) shall be removed and returned to the City of Joliet within ten (10) days. If the applicant fails to remove the sign within ten days, the City of Joliet may remove the sign, and the cost of the removal shall be deducted from the applicant's sign deposit. Please allow approximately 10-15 days for sign deposit refund processing.

Failure to post the notice sign as required may result in the deferral of action on, or the denial of the applicant's petition.

EXAMPLES:

PLAT OF SURVEY

LOT 7, EXCEPT THE NORTH 80 FEET THEREOF, IN KATHERINE S. NICHOLSON'S SUBDIVISION OF THE SOUTHWEST PART OF BLOCK 49, OF THE CANAL TRUSTEES' SUBDIVISION OF THE WEST HALF OF SECTION 9, IN TOWNSHIP 35 NORTH, AND IN RANGE 10 EAST OF THE THIRD PRINCIPAL MERIDIAN, ACCORDING TO THE PLAT THEREOF RECORDED MAY 3, 1901 IN PLAT BOOK 11, PAGE 66, SITUATED IN THE CITY OF JOLIET, WILL COUNTY, ILLINOIS.

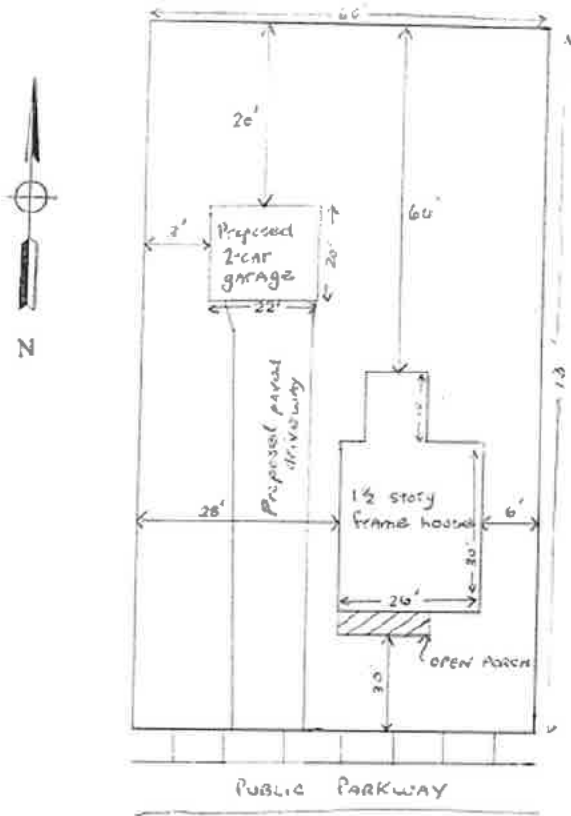

Sample Site Plan
(For illustrative purposes only)



Sample Floor Plan
(For illustrative purposes only)

FOR OFFICE USE ONLY

***Verified by Planner (please initial): _____ ***

Payment received from:

Petition #: _____

Common Address: _____

Date filed: _____

Meeting date assigned: _____

ZONING BOARD OF APPEALS

JOLIET, ILLINOIS

PETITION FOR VARIATION/APPEAL

City of Joliet Planning Division, 150 W. Jefferson St., Joliet, IL 60432

Ph (815)724-4050 Fax (815)724-4056

ADDRESS FOR WHICH VARIATION IS REQUESTED: 16329 S Boulevard Place

PETITIONER'S NAME: David Mikel - SES Branding

HOME ADDRESS: _____ ZIP CODE: _____

BUSINESS ADDRESS: 6001 Nimitz Parkway, South Bend, IN ZIP CODE: 46628

PHONE: (Primary) [REDACTED] (Secondary) [REDACTED]

EMAIL ADDRESS: [REDACTED] FAX: _____

PROPERTY INTEREST OF PETITIONER: Agent of property owner

OWNER OF PROPERTY: Edward McGowan, Managing Member, 5530 Acquisition, LLC

HOME ADDRESS: _____ ZIP CODE: _____

BUSINESS ADDRESS: 5420 W 112nd St., Alsip, IL ZIP CODE: 60803

EMAIL ADDRESS: [REDACTED] FAX: _____

Any use requiring a business license shall concurrently apply for a business license and submit a copy with this petition. Additionally, if this request is for operation of a business, please provide the following information:

BUSINESS REFERENCES (name, address, phone or email):

OTHER PROJECTS AND/OR DEVELOPMENTS:

PERMANENT INDEX NUMBER (TAX NO. OR P. I. N.): 0603234010070000 ;
_____ ; _____ ; _____ .

Property Index Number/P.I.N. can be found on tax bill or Will County Supervisor of Assessments website

LEGAL DESCRIPTION OF PROPERTY (an attached copy preferred):

LOT 7 The Boulevard Unit 4, a ReSub of Lots 2, 3 & 4 in Unit 2 of The Boulevard PUD, being
a Sub in Sec 23, T36N-R9E.

LOT SIZE: WIDTH: _____ DEPTH: _____ AREA: 1.51 acres

PRESENT USE(S) OF PROPERTY: vacant

PRESENT ZONING OF PROPERTY: B3

VARIATION/APPEAL REQUESTED: Request to place more than one sign (2) on two separate elevations.
Allowed 241.8 SF, proposing 315 SF

RESPONSE TO VARIATION CRITERIA

The Zoning Board of Appeals is authorized to grant or recommend relief only when it has received adequate evidence to establish a practical difficulty or hardship. The evidence must support each of the following three conditions:

- (a) The property in question cannot yield a reasonable return by use permitted and subject to the conditions allowed by the regulations in the particular district or zone.
- (b) The plight of the owner is due to unique circumstances.
- (c) The variation, if granted, will not alter the essential character of the locality.

Please describe how this request meets the criteria by responding to the following questions in your own words.

1. How do the applicable zoning regulations prevent the property in question from yielding a reasonable return?
See attached document.

2. What unique circumstances exist which mandate a variance?

See attached document.

3. What impact would the granting of this variance have upon the essential character of the general area? Please include both positive and negative impacts.

See attached document.

REQUIRED SUPPORTING ATTACHMENTS

- Site plan / concept plan / floor plan / building elevation plan
- Joliet Ownership Disclosure form
- Business license application (if applicable)

NOTARIZATION OF PETITION

STATE OF ^{Indiana} ~~ILLINOIS~~ ss
COUNTY OF ~~WILL~~ ^{St. Joseph}

I, [redacted], depose and say that the above statements are true and correct to the best of my knowledge and belief. I agree to be present in person or by representation when this petition is heard before the Zoning Board of Appeals.

[redacted signature area]

Owner's Signature
(If other than petitioner)

Subscribed and sworn to before me
this 29th day of January, 20 26

[redacted notary area]

CITY OF JOLIET OWNERSHIP DISCLOSURE FORM

The City of Joliet requires that applicants for zoning relief, subdivision approval, building permits and business licenses disclose the identity of all persons having an ownership interest in the business and the real property associated with the application. A copy of this form must be completed and submitted with other application materials. Failure to properly complete and submit this form may result in the denial of the application.

I. INFORMATION ABOUT THE APPLICATION

This form is submitted as part of an application for the following (check all that apply):

- Rezoning, Special Use Permit, Variation, or Other Zoning Relief (Complete Sections II and III)
- Preliminary Plat, Final Plat, or Record Plat of Subdivision (Complete Sections II and III)
- Building Permit (Complete Sections II and III)
- Business License (Complete All Sections)

II. INFORMATION ABOUT THE PROPERTY

The address and PIN(s) of the real property associated with this application are:

16329 S Boulevard Place, Joliet, IL 60586

PIN(s): 06-03-23-401-007-0000

III. PROPERTY OWNERSHIP

Select the type of owner of the real property associated with this application and fill in the appropriate contact information below:

- Individual:** State the names, addresses, and phone #'s of the individual owner(s)
- Corporation:** State the names, addresses, and phone #'s of all persons holding 3% or more of the stock of the corporation and the percentage of shares held by such stockholders
- Limited Liability Company:** State the names, addresses, and phone #'s of all members of the company along with the percentage of ownership held by each member
- Land Trust:** State the names, addresses, and phone #'s of the trustee(s) and all beneficiaries
- Partnership:** State the names, addresses, and phone #'s of all partners
- Other type of organization:** State the names, addresses, and phone #'s of all persons having a legal or equitable ownership interest in the organization or the right to direct the affairs of the organization

SSBO Acquisition, LLC
5420 W. 122nd Street
Alsip, IL, 60803

E-MAIL: [REDACTED] FAX: _____

IV. BUSINESS OWNERSHIP

If the owner of the business is different than the owner of the real property associated with the application, then the following information must be provided:

Select the type of business owner associated with this application and fill in the contact information below:

- Individual:** State the names, addresses, and phone #'s of the individual owner(s)
- Corporation:** State the names, addresses, and phone #'s of all persons holding 3% or more of the stock of the corporation and the percentage of shares held by such stockholders
- Limited Liability Company:** State the names, addresses, and phone #'s of all members of the company along with the percentage of ownership held by each member
- Partnership:** State the names, addresses, and phone #'s of all partners
- Other type of organization:** State the names, addresses, and phone #'s of all persons having a legal or equitable ownership interest in the organization

E-MAIL: _____ FAX: _____

NOTE:
If a stockholder, member, beneficiary or partner disclosed in Section III or Section IV is not an individual, then the individuals holding the legal or equitable title to the real property or business associated with the application must also be disclosed. For example, if the real property associated with an application is owned by a land trust, and the beneficiary of the land trust is a limited liability company, then the members of the limited liability company must be disclosed. If one of the members of the limited liability company is a partnership, then the identity of the partners must be disclosed. If one of the partners is a corporation, then all persons owning 3% or more of the issued stock must be disclosed.

SIGNED: _____

DATE: 1-28-2020 _____

Name, Title, and Telephone Numbers of Person Completing and Submitting This Form:

PRINT

How to Post a Sign for any Land Use Change

In an effort to increase the awareness of neighborhoods of potential land use changes in their areas, the City of Joliet requires posting of a sign giving notice of a hearing on a proposed land use change. All petitions filed for review by the Zoning Board of Appeals and Plan Commission must follow these procedures:

1. At least one sign for every 500 feet of street frontage, with a minimum of one sign on each street abutting the property shall be posted. If the property in question is more than 1 acre please refer to page 2 for information.
2. The sign shall be posted at least 15 days but not more than 30 days before the hearing date.
3. The sign shall contain the time and place of the public hearing and the nature of the land use change being requested. It shall be placed in a conspicuous location on the property so it may be observed and read from the street.
4. The sign shall be provided by the City of Joliet Planning Division upon the applicant's payment of a \$50.00 deposit for each sign.
5. It shall be the applicant's responsibility to post the sign. Written certification of the posting of the sign shall be provided by the applicant to the City with the date and location of the posting of the sign.
6. Upon completion of the public hearing, the sign shall be removed and returned to the City within ten days. The applicant's deposit shall be refunded upon return of the sign.
7. Failure to post the sign as required may result in the deferral of action on, or the denial of, the applicant's petition.

Requirements For Posting Land Use Change Informational Signs

(6) Land Use Change Informational Signs: In addition to the publication of newspaper notice for a public hearing on any request for a land use change (such as a petition for a variation, special exception, variation of use, or zoning reclassification) and any request for subdivision approval (preliminary plat), notice of a public hearing on such land use change shall be given by posting one or more land use change informational signs on the subject property in accordance with the following provisions:

(A) For parcels comprising 1 acre or more:

- (1) The applicant or the applicant’s agent shall erect a sign or signs with minimum dimensions of three (3) by four (4) feet. The number and location of the sign(s) shall be determined by the City Manager or his designee.
- (2) The sign(s) shall conform to the format provided by the City Manager or his designee and shall contain the time and place of public hearing and the nature of the application (SEE BELOW)
- (3) The sign(s) shall be posted at least 15 days but not more than 30 days before the public hearing date.
- (4) It shall be the responsibility of the applicant to prepare and create such signs and to erect whatever framework that may be necessary to display the signage.
- (5) Upon completion of the public hearing, the sign(s) shall be removed within 10 days. If the applicant fails to remove the sign, the City of Joliet may remove the sign, and the cost of such removal shall be billed to the applicant and shall constitute a debt payable to the City.

**NOTICE OF PUBLIC MEETING
CITY OF JOLIET, IL**

DATE/TIME: _____

LOCATION: City Hall Council Chambers
150 W. Jefferson St., Joliet

DESCRIPTION OF REQUEST:

FOR MORE INFORMATION CALL: 815-724-4040 OR
815-724-4050

**COMMUNITY DEVELOPMENT DEPARTMENT
CITY OF JOLIET**



Restaurant #23L0046

NEC of U.S. Rte 30 & The Boulevard Joliet, IL 60431



Ph: 1.800.599.7696
Fax: 1.574.237.6166

www.siteenhancementservices.com



TRAFFIC PATTERNS

Restaurant # 23L0046
NEC of U.S. Rte 30 & The Boulevard Joliet, IL 60431



SITE PLAN

- A** 36" Channel Letters on Raceway: 68.9 SF
- B** 3'-9" x 5'-3" Steer Logo: 19.7 SF
- C** 36" Channel Letters on Raceway: 68.9 SF
- D** 36" Channel Letters on Raceway: 68.9 SF
- E** 3'-9" x 5'-3" Steer Logo: 19.7 SF
- F** 36" Channel Letters on Raceway: 68.9 SF
- G** Custom 11 3/4" x 5'-6" Tenant Panel on Shared Sign: 5.6 SF
See aerial for shared sign location
- H** Custom 11 3/4" x 5'-6" Tenant Panel on Shared Sign: 5.6 SF
See aerial for shared sign location

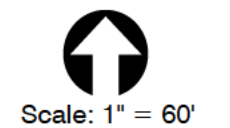
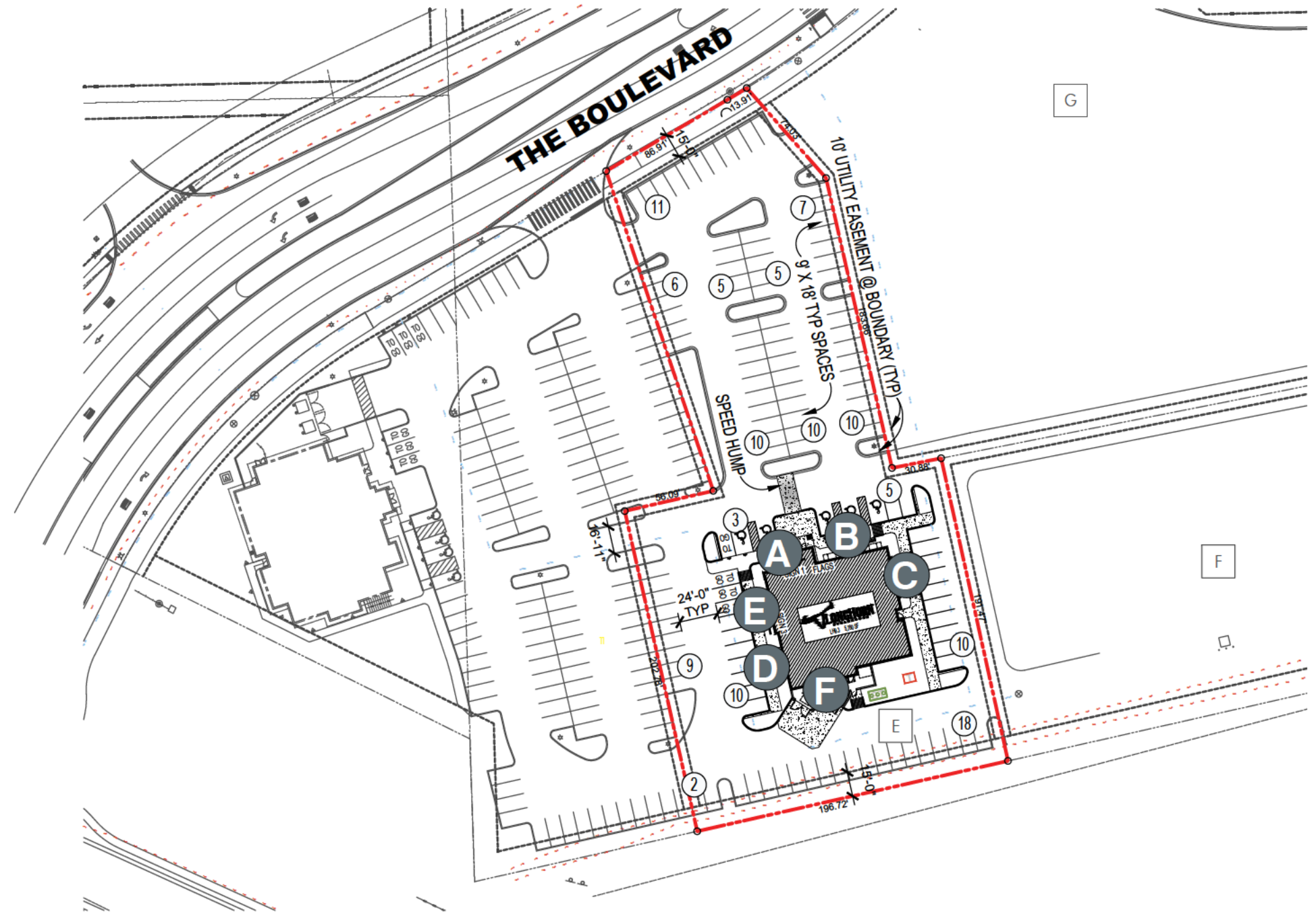

FRONT ELEVATION

Restaurant # 23L0046
 NEC of U.S. Rte 30 & The Boulevard Joliet, IL 60431



Scale: 3/32" = 1'



A 36" Channel Letters on Raceway (Internally Illuminated w/ LED)
 Utilized Square Footage: 68.9 SF
 Scale: 1/4"=1'



ILLUMINATION VIEW

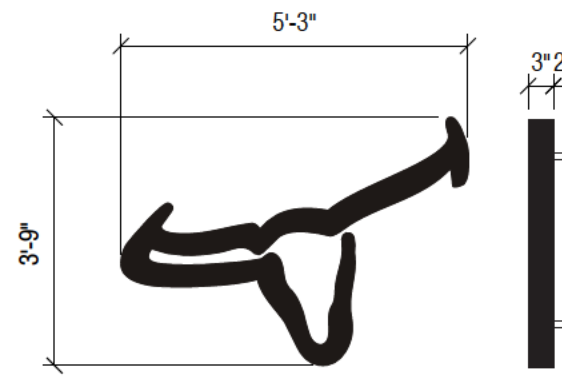

B Steer Logo (Halo Illuminated w/ LED)
 Utilized Square Footage: 19.7 SF
 Scale: 3/8"=1'



ILLUMINATION VIEW





LEFT ELEVATION

Restaurant # 23L0046
 NEC of U.S. Rte 30 & The Boulevard Joliet, IL 60431



Scale: 3/32" = 1'



C 36" Channel Letters on Raceway (Internally Illuminated w/ LED)
 Utilized Square Footage: 68.9 SF
 Scale: 1/4" = 1'



ILLUMINATION VIEW





RIGHT ELEVATION



Scale: 3/32" = 1'

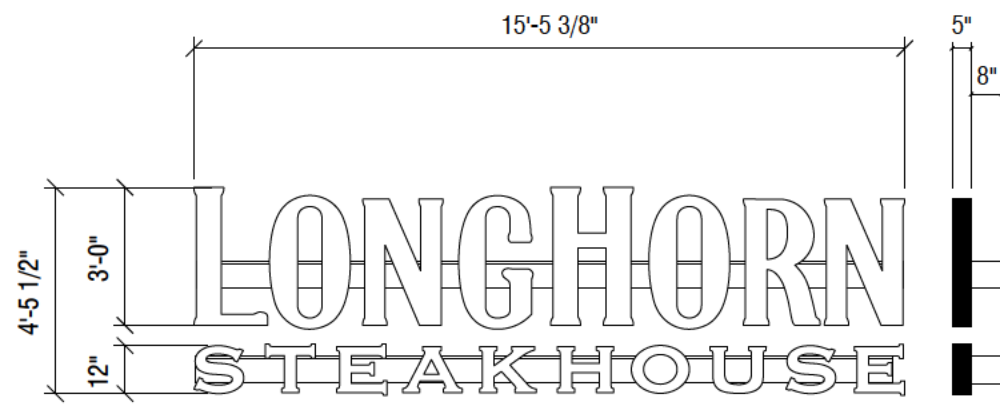

D 36" Channel Letters on Raceway (Internally Illuminated w/ LED)
 Utilized Square Footage: 68.9 SF
 Scale: 1/4"=1'



ILLUMINATION VIEW

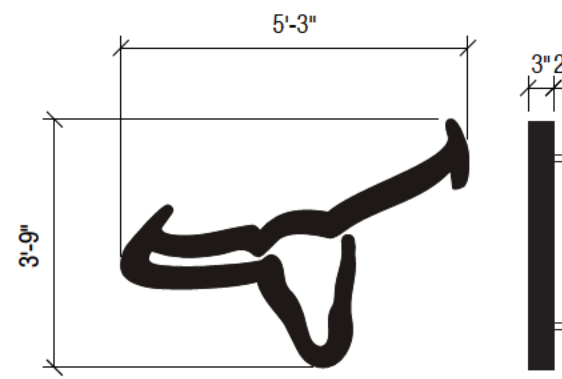

E Steer Logo (Halo Illuminated w/ LED)
 Utilized Square Footage: 19.7 SF
 Scale: 3/8"=1'



ILLUMINATION VIEW





REAR ELEVATION



Scale: 3/32" = 1'



F 36" Channel Letters on Raceway (Internally Illuminated w/ LED)
 Utilized Square Footage: 68.9 SF
 Scale: 1/4" = 1'



ILLUMINATION VIEW





GROUND SIGN

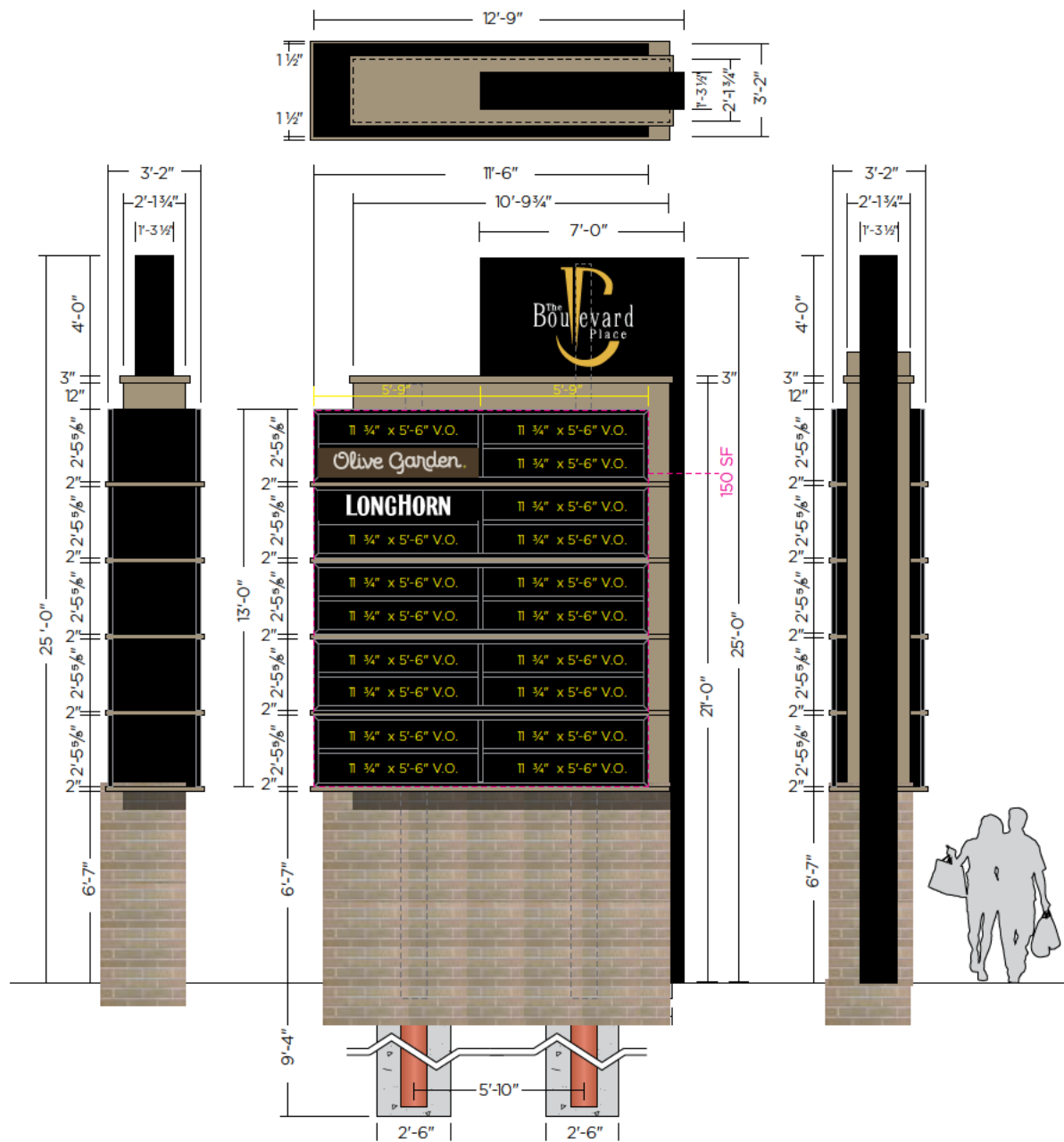

Scale: 1/8" = 1'



- G** Custom 11' 3/4" x 5' 6" Tenant Panel on D/F Shared Monument
- H** Utilized Square Footage: 5.6 SF
- H** Scale: 1"=1'



A
C
D
F



MATERIAL FINISH COLORS			
Returns	Faces	Faces	Trimcap
Pre-finished Aluminum Matte Black finish	7328 White Acrylic	2283 Red Acrylic w/ 3M 3635-210 White Perforated Vinyl	Black

RACEWAY COLORS		
Option 1	Option 2	Option 3
Benjamin Moore #063 "Pennies from Heaven"	Benjamin Moore "Brookline Beige" HC 47	Benjamin Moore "Country Redwood" HC-183
Quantity	Quantity	Quantity

ELECTRICAL REQUIREMENTS

Total: T.B.D. Amps

(1) 120V 20A Circuit Required.

ALL BRANCH CIRCUITS SHALL BE DEDICATED TO SIGNS (INCLUDING GROUND AND NEUTRAL) AND SHALL NOT BE SHARED WITH OTHER LOADS.

LH-36RW / INTERNALLY ILLUMINATED CHANNEL LETTERS ON RACEWAYS / TOTAL: 68.90 SQ.FT.

QTY: ONE (1) SCALE : 1/2" = 1'-0"

"LONGHORN":
FACES: (.187) #2283 RED ACRYLIC W/ 3m # 3635-210 WHITE PERFORATED VINYL APPLIED 1ST SURFACE
 (LETTERS TO APPEAR WHITE DURING DAY & RED AT NIGHT).
RETURNS: 5" DEEP, .040 PRE-FINISHED MATTE BLACK ALUMINUM W/ BLACK TRIMCAP.
NOTE: INTERIOR OF LETTERS TO BE PAINTED W/ WHITE LIGHT ENHANCEMENT PAINT.
ILLUMINATION: GE RED LED MODULES & POWER SUPPLIES(PER GE LAYOUT)

"STEAKHOUSE":
FACES: (.187) #7328 WHITE ACRYLIC.
RETURNS: 5" DEEP, .040 PRE-FINISHED MATTE BLACK ALUMINUM W/ BLACK TRIMCAP.
NOTE: INTERIOR OF LETTERS TO BE PAINTED W/ WHITE LIGHT ENHANCEMENT PAINT.
ILLUMINATION: GE WHITE LED MODULES & POWER SUPPLIES(PER GE LAYOUT)

CUSTOMER TO PROVIDE:
 (For New / Remodel Construction) ADEQUATE BEHIND THE WALL BACKING AND ACCESS AS REQUIRED TO INSTALL SIGNAGE. CUSTOMER TO FORWARD COPY OF FINAL APPROVED SIGNAGE DRAWINGS TO BUILDING SITE CONTACT SO THAT THESE PROVISIONS CAN BE MADE DURING CONSTRUCTION AND PRIOR TO SIGN INSTALLATION.

ALL BRANCH (PRIMARY ELECTRICAL SERVICE) CIRCUITS & FINAL CONNECTION TO EACH SIGN (WITHIN 5 FT.) TO BE BY CERTIFIED ELECTRICIAN:

- All branch circuits for signs must be totally dedicated to signs (including dedicated ground and dedicated neutral per circuit).
- Sign circuits must not be shared with other loads such as lighting, air conditioning, and other equipment.
- Properly sized ground wire that can be traced back to the breaker panel must be provided.
- Number and size of circuits for each sign to meet Federal Health Sign's requirement.

Any deviation from the above recommendations may result in:

- Damage to or improper operation of the sign(s).
- Delays and additional costs.

Notes:

- Certain electrical components of signs will fail prematurely if signs are not shut-off for a period of time, once, each day. For best performance, we recommend signs to be connected to an automatic controlling device such as an Energy Management System, Time Clock or Photo Cell that will automatically shut-off the sign for a period of time, each day. Failure to do so will cause damage to the electrical components of the sign and will void the warranty.
- Some dimming devices will also adversely affect sign electrical components, causing failure. Any dimming of the sign without consultation with Federal Health Sign Co. will void the warranty.

INSTALLER IS RESPONSIBLE FOR:

PROVIDING AND INSTALLING ALL COMPONENTS REQUIRED TO RUN SECONDARY WIRING (CONNECTORS, GTO CONDUIT, ETC.) TO BE DETERMINED BY LOCAL CODE AND SITE CONDITIONS.

PROVIDING ALL NEEDED INSTALLATION HARDWARE AS DETERMINED BY LOCAL CODE AND SITE CONDITIONS.

SEALING BUILDING PENETRATIONS WITH SILICONE TO PREVENT MOISTURE PENETRATION @ EXTERIOR LOCATIONS.

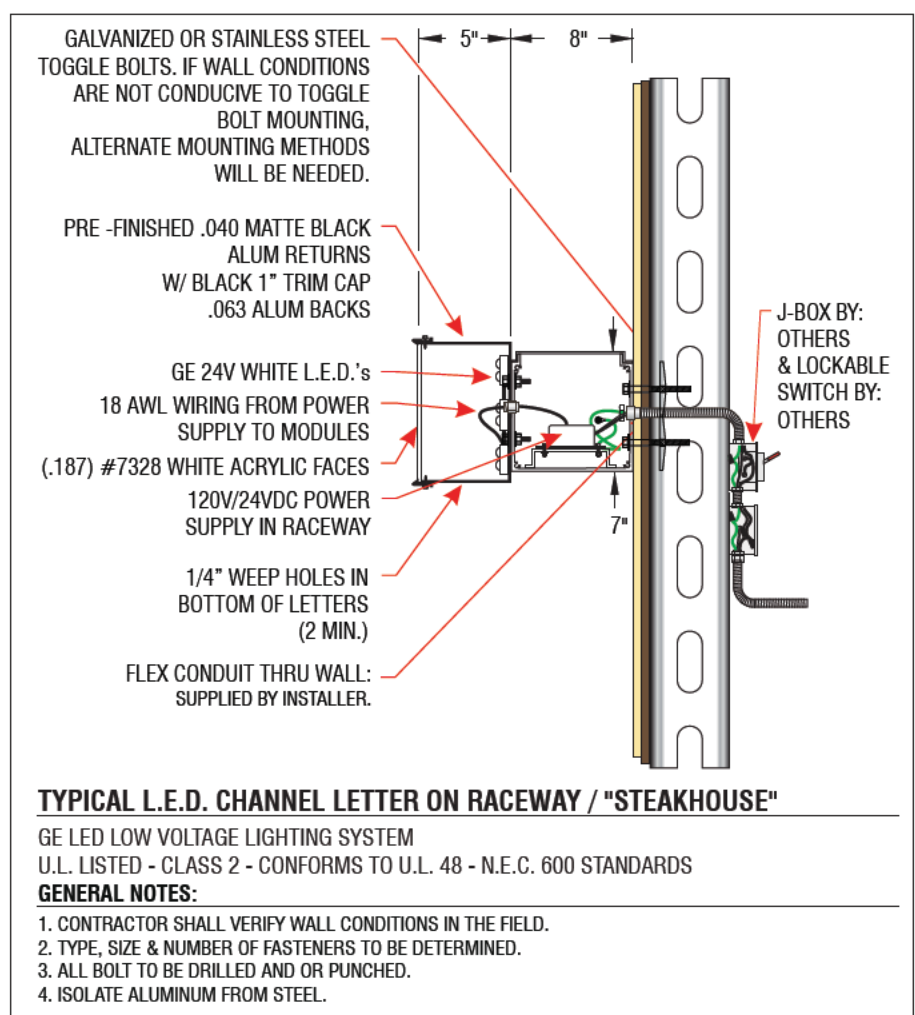
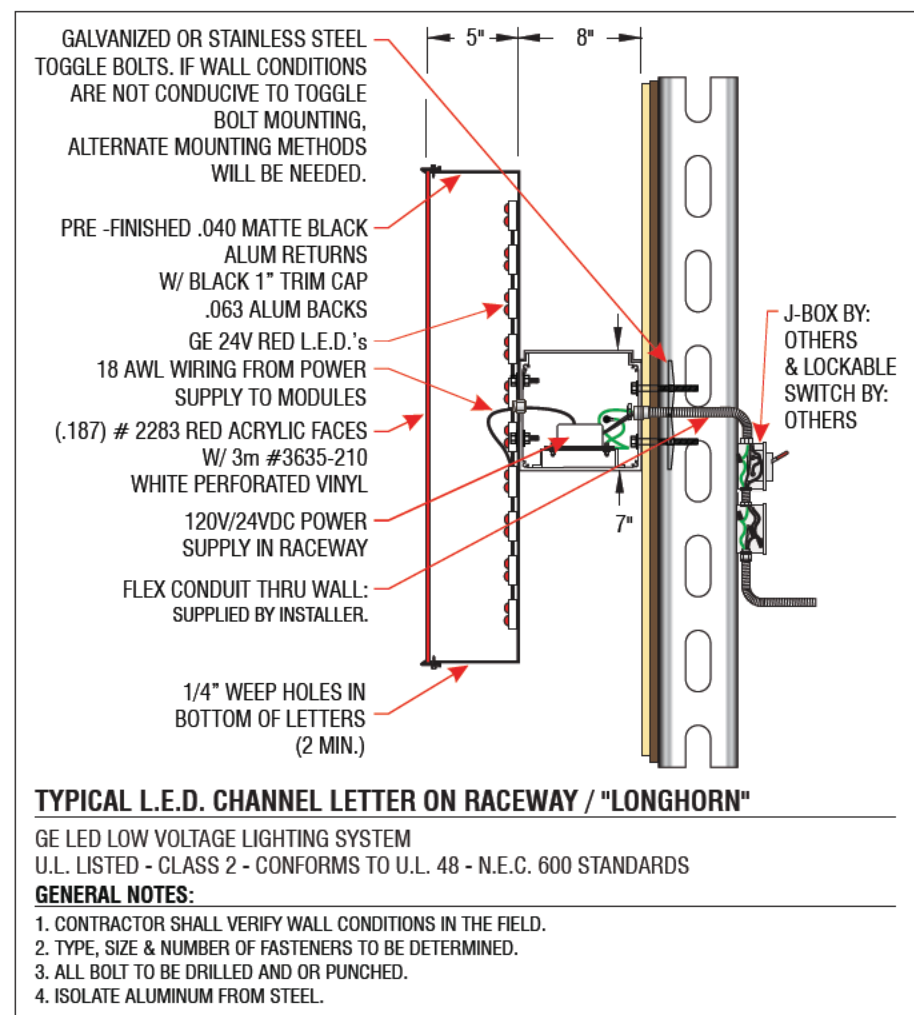

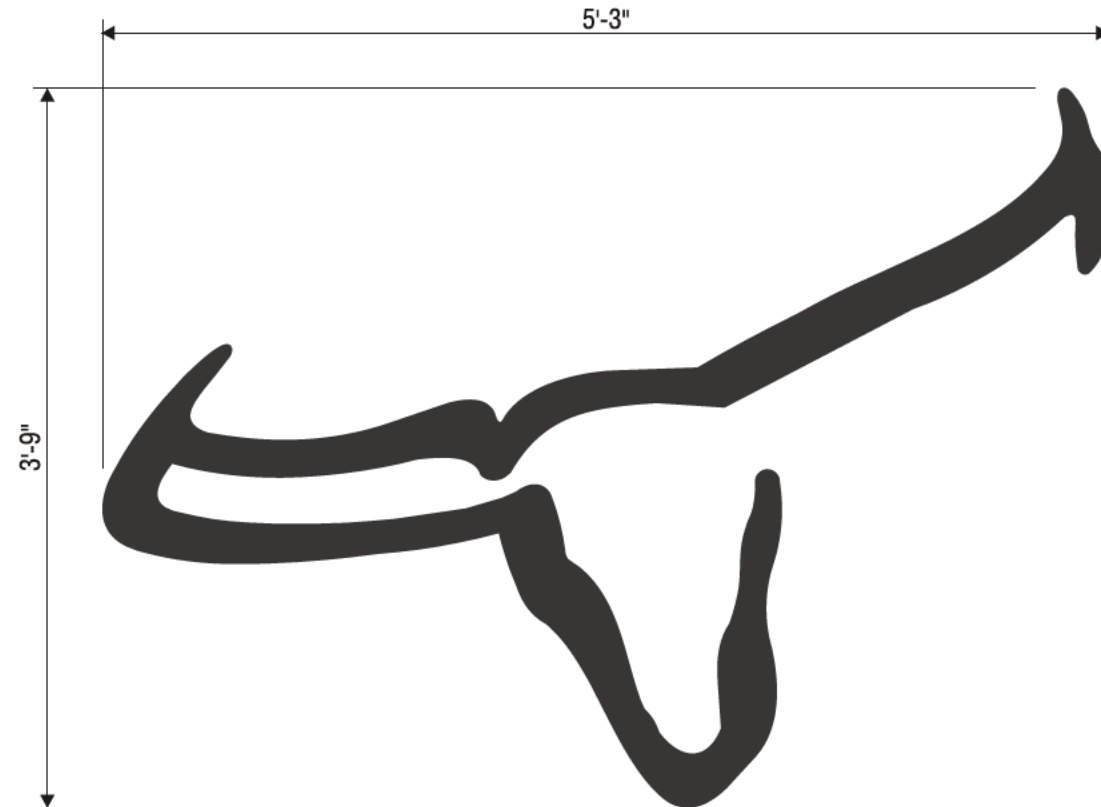

LH-45STEER / HALO-ILLUMINATED REVERSE CHANNEL STEER / 19.68 SQ.FT.

"LONGHORN":

FACE & RETURNS: FABRICATED FROM ALUMINUM & PAINTED SATIN BLACK FINISH.

NOTE: INTERIOR OF LETTERS TO BE PAINTED W/ WHITE LIGHT ENHANCEMENT PAINT.

ILLUMINATION: GE WHITE LED MODULES POWERED BY REMOTE POWER SUPPLIES.(PER GE LAYOUT)

SCALE : 1" = 1'-0"

CUSTOMER TO PROVIDE:

(For New / Remodel Construction) ADEQUATE BEHIND THE WALL BACKING AND ACCESS AS REQUIRED TO INSTALL SIGNAGE. CUSTOMER TO FORWARD COPY OF FINAL APPROVED SIGNAGE DRAWINGS TO BUILDING SITE CONTACT SO THAT THESE PROVISIONS CAN BE MADE DURING CONSTRUCTION AND PRIOR TO SIGN INSTALLATION.

ALL BRANCH (PRIMARY ELECTRICAL SERVICE) CIRCUITS & FINAL CONNECTION TO EACH SIGN (WITHIN 5 FT.) TO BE BY CERTIFIED ELECTRICIAN:

- A. All branch circuits for signs must be totally dedicated to signs (including dedicated ground and dedicated neutral per circuit).
- B. Sign circuits must not be shared with other loads such as lighting, air conditioning, and other equipment.
- C. Properly sized ground wire that can be traced back to the breaker panel must be provided.
- D. Number and size of circuits for each sign to meet Federal Heath Sign's requirement.

Any deviation from the above recommendations may result in:

- 1. Damage to or improper operation of the sign(s).
- 2. Delays and additional costs.

Notes:



- Ⓢ Certain electrical components of signs will fail prematurely if signs are not shut-off for a period of time, once, each day. For best performance, we recommend signs to be connected to an automatic controlling device such as an Energy Management System, Time Clock or Photo Cell that will automatically shut-off the sign for a period of time, each day. Failure to do so will cause damage to the electrical components of the sign and will void the warranty.
- Ⓢ Some dimming devices will also adversely affect sign electrical components, causing failure. Any dimming of the sign without consultation with Federal Heath Sign Co. will void the warranty.

INSTALLER IS RESPONSIBLE FOR:

PROVIDING AND INSTALLING ALL COMPONENTS REQUIRED TO RUN SECONDARY WIRING (CONNECTORS, GTO CONDUIT, ETC.) TO BE DETERMINED BY LOCAL CODE AND SITE CONDITIONS.

PROVIDING ALL NEEDED INSTALLATION HARDWARE AS DETERMINED BY LOCAL CODE AND SITE CONDITIONS.

SEALING BUILDING PENETRATIONS WITH SILICONE TO PREVENT MOISTURE PENETRATION @ EXTERIOR LOCATIONS.

MATERIAL FINISH COLORS	
Face & Returns	Logo Back
	
Satin Black Painted Aluminum	Clear Polycarbonate

ELECTRICAL REQUIREMENTS
Total: <u>.3</u> Amps
(1) 120V 20A Circuit Required.
ALL BRANCH CIRCUITS SHALL BE DEDICATED TO SIGNS (INCLUDING GROUND AND NEUTRAL) AND SHALL NOT BE SHARED WITH OTHER LOADS.

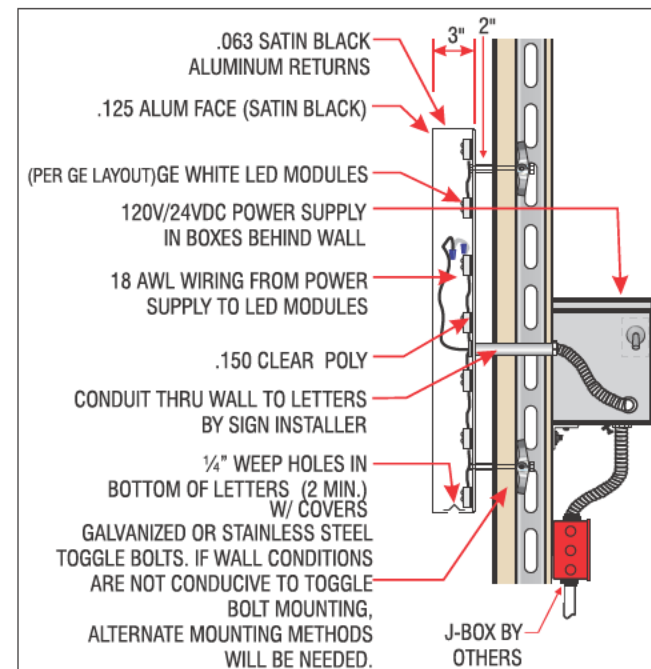

TYPICAL L.E.D. REVERSE CHANNEL "STEER"

GE LED LOW VOLTAGE LIGHTING SYSTEM

U.L. LISTED - CLASS 2 - CONFORMS TO U.L. 48 - N.E.C. 600 STANDARDS

GENERAL NOTES:

- 1. CONTRACTOR SHALL VERIFY WALL CONDITIONS IN THE FIELD.
- 2. TYPE, SIZE & NUMBER OF FASTENERS TO BE DETERMINED.
- 3. ALL BOLT TO BE DRILLED AND OR PUNCHED.
- 4. ISOLATE ALUMINUM FROM STEEL.

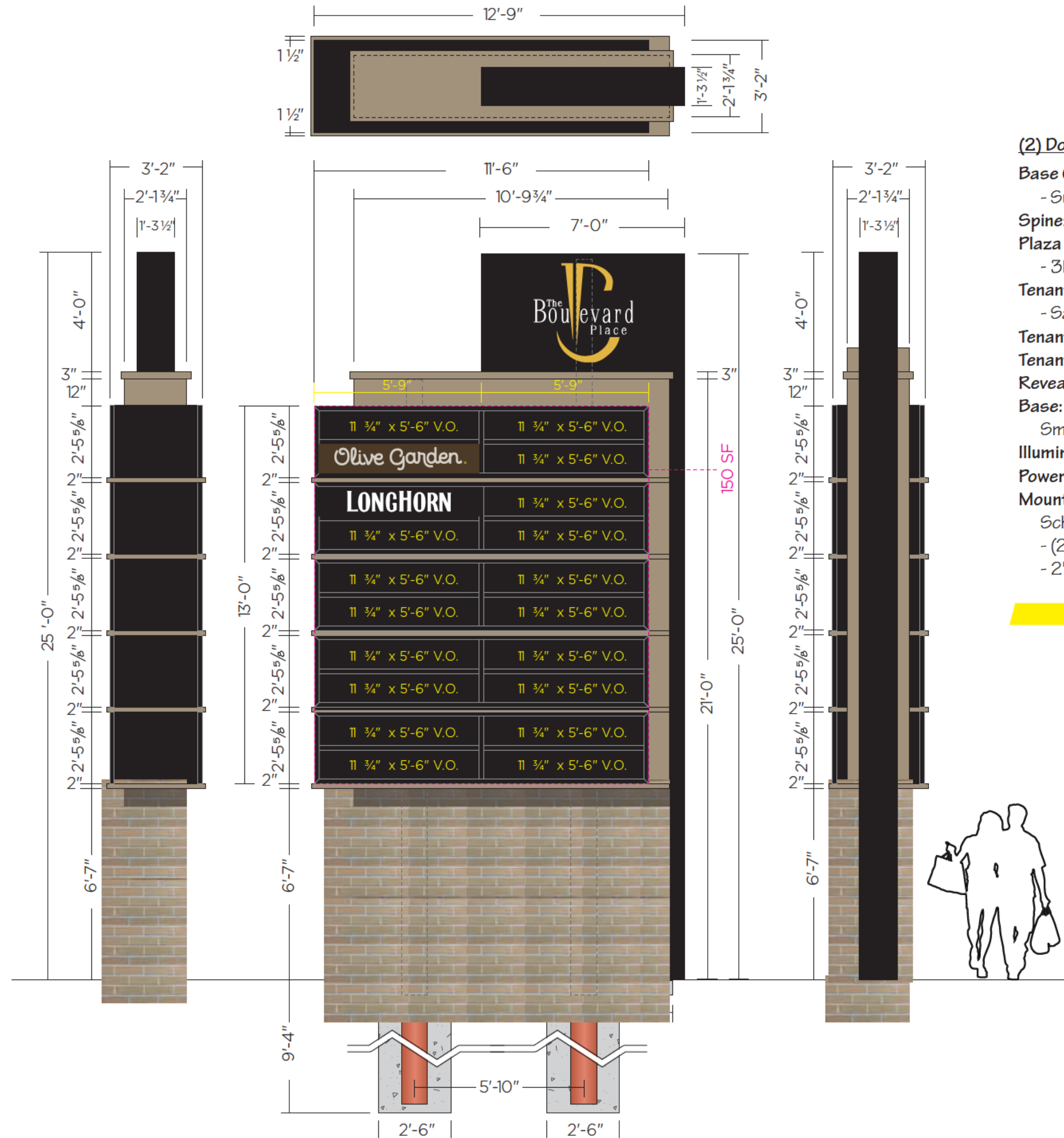

(2) Double Face Illuminated Monument Signs

Base Cabinet & Cap: Fabricated Aluminum Painted to Match Brick - Color T.B.D.

- Suede Finish

Spine: Fabricated Aluminum Painted Black - Satin Finish

Plaza Graphics: Routed & Backed w/ White Acrylic

- 3M 3630-25 Sunflower Translucent Vinyl Applied

Tenant Cabinet / Retainers / Dividers: Fabricated Aluminum Painted Black

- Satin Finish

Tenant Panels: White Polycarbonate w/ 3M 7725-12 Black Vinyl Applied

Tenant Graphics: T.B.D.

Reveals: Aluminum Tubes Painted to Match Brick - Color T.B.D.

Base: Masonry by Others - Brick Veneer #4 - Glen-Gery Dunes Gray

Smooth Sioux City Brick (Utility)

Illumination: White LEDs w/ 12V 60W 120/277V Power Supplies

Power: (1) 20Amp @ 120Volts Electrical Circuit Run to Site by Others

Mounting: (2) 10" (10 3/4" O.D.) Std. Steel Pipes w/ (2) 6" (6.625" O.D.)

Sch. 40 Steel Pipes Sleeved - Welded

- (2) 2'-6" dia. x 9'-4" deep Concrete Foundations

- 2'-6" W x 11'-1" L x 6" deep Concrete Pad for Masonry



BRICK COLOR "B" GLEN-GERY DUNES
GRAY SMOOTH SIOUX CITY BRICK
(UTILITY)



BOULEVARD PLACE: PLANNED DEVELOPMENT DESIGN GUIDELINES

August, 2019

Prepared by Houseal Lavigne

TABLE OF CONTENTS

Intent and Applicability _____	1	Building Layout and Dimensional Standards _____	19
Intent _____	1	Building Façades _____	19
Applicability _____	1	Building Height _____	20
Relationship to Zoning and Subdivision Ordinances _____	2	Building Design Standards _____	20
Design Guidelines General Framework _____	2	Primary Façade Design _____	21
Suppression of Plainfield and Joliet Codes _____	2	Secondary Façade Design _____	22
Applicable Zoning _____	2	Tertiary Façade Design _____	22
Building Code _____	2	Open Space _____	23
Administration _____	3	Application of Design Guidelines _____	23
Procedures _____	3	Definitions _____	23
Interpretations _____	5	Exhibit 01 _____	24
Permitted Land Uses _____	6		
Performance Standards _____	7		
Site Development Standards _____	7		
Signs _____	7		
Parking and Loading _____	13		
Landscape _____	15		
Screening _____	18		



INTENT AND APPLICABILITY

Intent





The Boulevard Place Planned Development covers approximately 171 acres of property located generally at the northwest corner I-55 and US Route 30, including areas in both the City of Joliet and the Village of Plainfield. The Planned Development designates a portion of Boulevard Place consisting of approximately 54 acres for commercial development. Approximately 18 acres of the commercial development is designated for a large box warehousing store which is not intended to be governed by these Design Guidelines. The remainder of the commercial development, consisting of Phases 2, 3 and 4 as depicted in Figure 1 and being comprised of approximately 36 acres (the “Subject Property”), shall be governed by these Design Guidelines. The intent is to establish a hybrid lifestyle shopping center with a pedestrian friendly, mixed-use environment.

The Boulevard Place Planned Development Design Guidelines have been developed to encourage the use of exciting and unique storefronts and gathering spaces to create a shopping environment that attracts customers and results in increased sales. Through careful planning each store and building should become inviting and effective retail establishments which will be compatible with the overall design and quality of the development. The streetscape should be designed to encourage patrons to linger and relax through well landscaped areas and pedestrian amenities. The various buildings which will comprise Boulevard Place should create a unique environment that makes the development a new destination for shopping and dining in the region.

Applicability

The City of Joliet and the Village of Plainfield each have independent regulations that govern development within their boundaries. However, these ordinances were not designed to function in a complementary fashion and, in some instances, contain directly conflicting provisions. In the spirit of intergovernmental cooperation and in an effort to bridge the differences between the applicable regulations of each community, The Boulevard Place Planned Development Design Guidelines have been established as mandatory development standards for the Subject Property and approved as part of The Boulevard Place Planned Development by each of Joliet and Plainfield. The Boulevard Place Planned Development Design Guidelines are intended supplant the zoning regulations of the applicable municipality in order to create a coherent and uniform set of standards to govern the development and operation of the Subject Property.

Figure 01

-  Phase 1
-  Phase 2
-  Phase 3
-  Phase 4

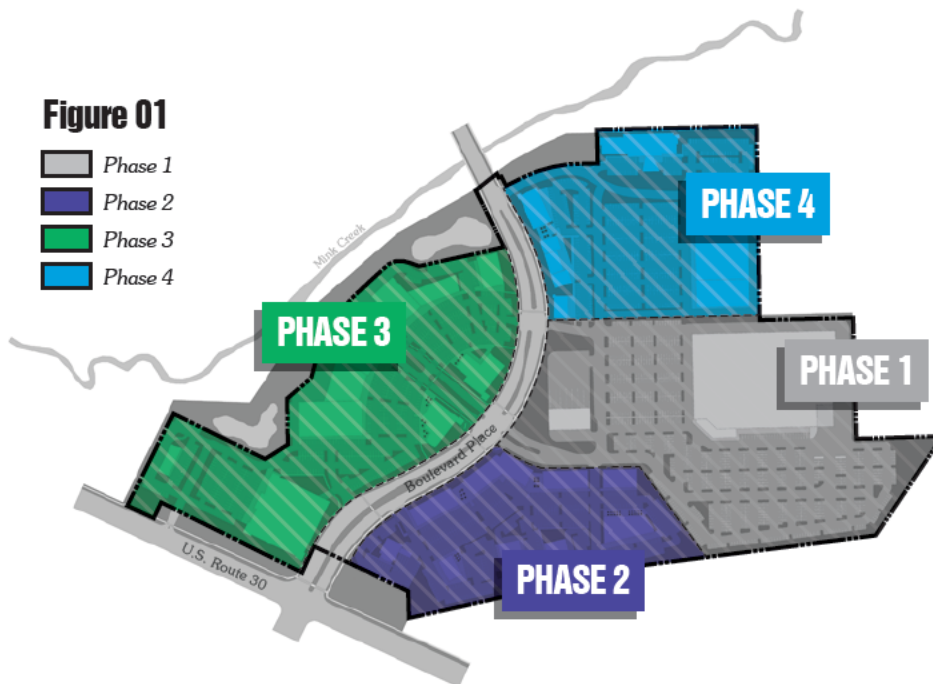

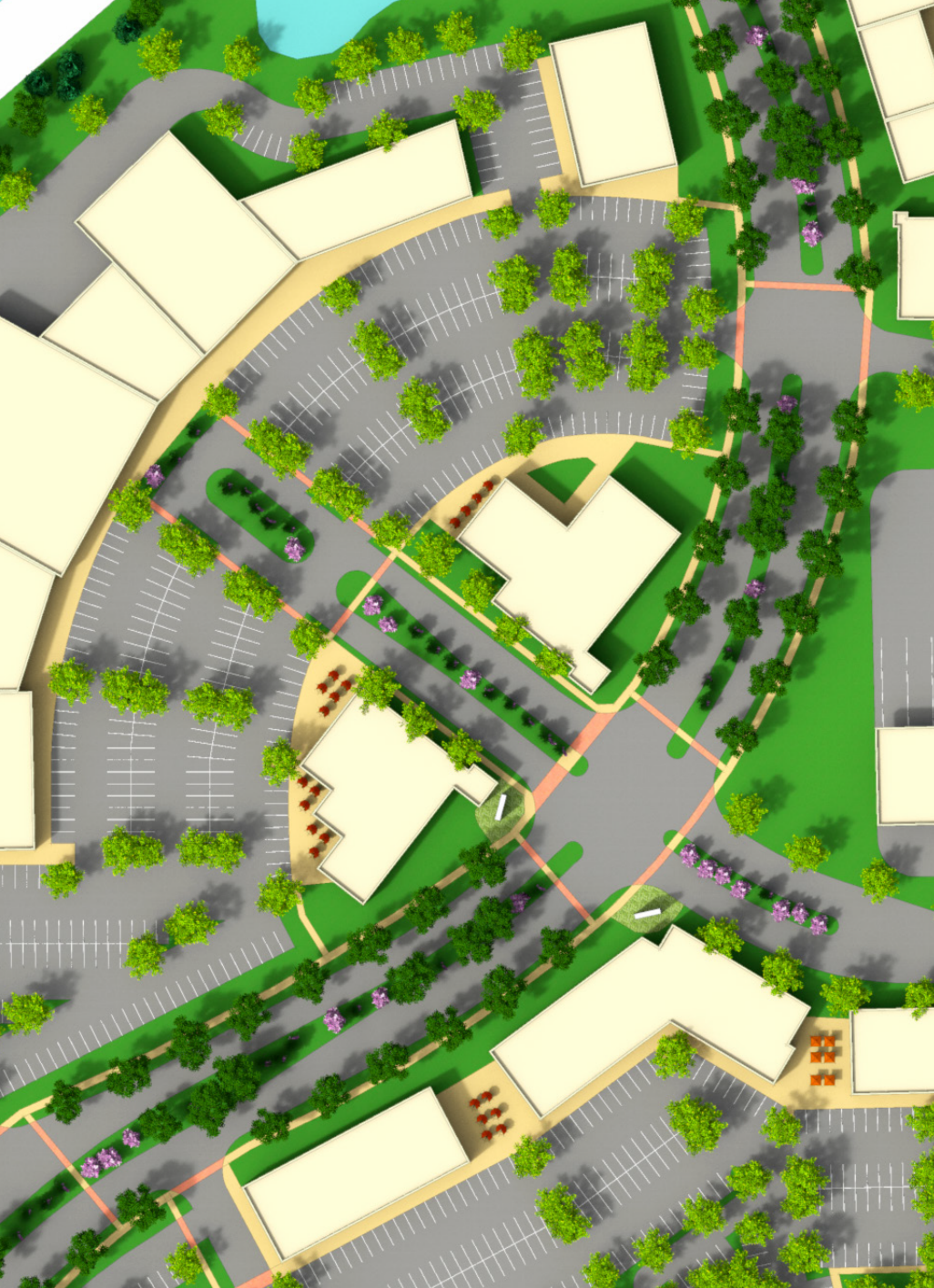

RELATIONSHIP TO ZONING AND SUBDIVISION ORDINANCES

Design Guidelines General Framework

The Design Guidelines are comprised of standards for permitted land uses, site development standards, building layout and dimensional standards, building design standards, and open space requirements.

Applicable Zoning

The Design Guidelines supersede the development standards of the Joliet and Plainfield zoning and sign ordinances. Where the Design Guidelines are silent on any matter relating to land use, building, or development, the applicable provisions of the municipal ordinances of governing jurisdiction shall apply, but only to the extent that the provisions do not conflict with these Design Guidelines.

Building Code

The provisions of The Boulevard Place Planned Development and the Design Guidelines are not intended, in any way, to modify or amend the provisions of the building codes or other applicable life safety ordinance or laws of Plainfield or Joliet. In any case where building codes or life safety regulations conflict with The Boulevard Place Planned Development, the building or life safety regulations shall apply.

ADMINISTRATION

Procedures

1. Jurisdiction.

a. Plainfield

- i. A portion of the subject property is located in the Village of Plainfield. The Village of Plainfield shall have sole and exclusive jurisdiction over the review and approval of plans for that portion of the subject property located in the Village of Plainfield. The Village acknowledges that portions of the subject property located in the Village of Plainfield will service buildings located in the City of Joliet and that portions of the subject property located in the City of Joliet will service buildings located in the Village of Plainfield. The Village acknowledges that it will benefit from areas within its jurisdiction that will service buildings located in the City of Joliet and will not withhold or otherwise delay the review and approval of plans, the signature of plats or the issuance of permits for said portions of the the subject property that may provide parking, signage or other benefits (consistent with these Design Guidelines) for that portion of the subject property located in the City of Joliet. Where any portion of the subject property is located entirely within the jurisdiction of the City of Joliet, the Village acknowledges that it shall have no authority to review plans or issues permits for said portion of the subject property.

b. Joliet

- i. A portion of the subject property is located in the City of Joliet. The City of Joliet shall have sole and exclusive jurisdiction over the review and approval of plans for that portion of the subject property located in the City of Joliet. The City acknowledges that portions of the subject property located in the City of Joliet will service buildings located in the Village of Plainfield and that portions of the subject property located in the Village of Plainfield will service buildings located in the City of Joliet. The City acknowledges that it will benefit from areas within its jurisdiction that will service buildings located in the Village of Plainfield and will not withhold or otherwise delay the review and approval of plans, the signature of plats or the issuance of permits for said portions of the subject property that may provide parking, signage or other benefits (consistent with these Design Guidelines) for that portion of the subject property located in the Village of Plainfield. Where any portion of the subject property is located entirely within the jurisdiction of the Village of Plainfield, the City acknowledges that it shall have no authority to review plans or issues permits for said portion of the subject property.

c. Intergovernmental Cooperation

- i. It is anticipated that the Village of Plainfield and the City of Joliet will enter into an intergovernmental agreement (IGA) concerning, among other things, the provision of utility services, police and fire services, snow plowing and the maintenance of public right-of-way. The IGA is intended to provide efficient utility services to the subject property and ensure uniform operation as a singular planned development between jurisdictions.

2. Pre-filing Review and Transmittal of Application.

a. Conference.

- i. A prospective applicant, prior to submitting a formal application for the development of any portion of the subject property, shall meet for a pre-filing conference(s) with the appropriate designee as defined herein, the designee, and any other Plainfield or Joliet official or employee designated by the designee. The purpose of the conference(s) is to help the applicant understand the vision, purpose, and intent of The Boulevard Place Planned Development, and the Design Guidelines, and the application requirements.

- b. Filing of Application. Following the completion of the pre-filing conference(s), the applicant shall file an application for the development of a site in The Boulevard Place Planned Development in accordance with this Section. The appropriate designee as defined herein shall deliver copies of the application to other Plainfield or Joliet departments for review and comment if deemed necessary by the designee.

- c. Deficiencies. The appropriate designee as defined herein shall determine whether the application is complete. If the designee determines that the application is not complete, he/she shall notify the applicant in writing of any deficiencies.

- d. Review by Designee. Upon receiving the complete application, the appropriate designee as defined herein shall determine whether the proposed development:

- i. Would constitute a minor change to The Boulevard Place Planned Development and Design Guidelines; or
- ii. Would constitute a major change to The Boulevard Place Planned Development and Design Guidelines.

- e. Major Change. Major Changes are modifications which alter the concept or intent of The Boulevard Place Planned Development or these Design Guidelines. Factors which shall be considered in determining whether a proposed change constitutes a major change include those which:

- i. Are inconsistent with the Intent and Purpose set forth herein;
- ii. Seek approval of a use not specifically permitted or substantially similar to a use permitted herein;
- iii. Require greater than 10 percent modification of the standards set forth herein; or
- iv. Require a deviation or variance from an otherwise applicable provision (one that has not been modified by these Design Guidelines or as set forth in the Planned Development Ordinance) of the Municipal Code of Plainfield or Joliet, whichever is applicable.

- f. Minor Change. Minor Changes are modifications that are not defined as major changes and do not alter the concept or intent of The Boulevard Place Planned Development or Design Guidelines. Final approvals of a site plan, landscape plan, engineering plans, and building elevations for each Phase or any sub phase of Boulevard Place shall be processed as a Minor Change unless a Major Change is required pursuant to the definition of a Major Change as set forth herein. Minor Changes shall be approved by the applicable jurisdiction provided that the application meets the requirements of these Design Guidelines and any other applicable municipal code provisions.

- g. Process for Review and Approval. The Major Change or Minor Change, as applicable, shall be processed in accordance with the applicable municipal code. All Major Changes shall require a public hearing before the applicable planning and zoning commission and shall be approved by ordinance of the Village Board or City Council, as appropriate. Minor Changes shall not require a public hearing, but shall be approved administratively, or at the Village's or City's sole discretion, may require approval by the Village Board or City Council by ordinance with the recommendation of the Plan Commission.

3. Application Requirements.

- a. The applicable municipal application for a major change, minor change, or planned development, whichever is applicable, shall be filed with the appropriate designee as defined herein. Said application shall specify whether it is for a Major Change or Minor Change and shall be in such form and accompanied by such information, as shall be determined by the designee. Every application shall contain, at a minimum, the following information, and related data:
 - i. The names and addresses of the owner of the subject site, the applicant, and all persons having an ownership or beneficial interest in the subject site and proposed planned site development.
 - ii. A statement from the owner of the subject site, if not the applicant, approving of the filing of the application by the particular applicant.
 - iii. A survey of, and legal description and street address for the subject site.
 - iv. A statement indicating compliance of the proposed planned site development with The Boulevard Place Planned Development and Design Guidelines, or if not compliant, the manner in which it is not compliant and justification for approval of a Major Change.
 - v. A scaled site plan showing the existing contiguous land uses, natural topographic features, development phase, public thoroughfares, transportation, and utilities along with the proposed planned site development showing building façade designation; building location and relation; build-to-line; and building separation.
 - vi. Schematic drawings illustrating the design and character of the building elevations. The drawings shall also include a schedule showing the number, type, and floor area of all uses or combinations of uses, and the floor area of the entire development.
 - vii. A landscaping plan showing the location, size, character and composition of vegetation and other material.
 - viii. Engineering plan, either final engineering or preliminary engineering, as may be appropriate based on whether applicant is seeking a Minor Change or a Major Change.
 - ix. A schedule of development showing the approximate date for beginning and completion of each stage of construction of the planned site development..

Interpretations

If uncertainty exists regarding the interpretation of terms, development standards, architectural standards, or any other regulation contain within these guidelines, the appropriate designee as defined herein shall determine the intent of the provision in question.

PERMITTED LAND USES

Permitted uses in The Boulevard Place Planned Development are reflected in Table 01.

1. Permitted Uses. Uses which are marked by a “P” in the table are allowed as a matter of right.
2. Conditional Uses. Uses which are marked by a “C” in the table shall require approval as a Major Change in order to determine if the use is appropriate in the context of the Purpose and Intent of The Boulevard Place Planned Development and these Design Guidelines.
3. Uses Not Permitted. Uses which are marked by a “X” in the table are prohibited, unless subsequently permitted as a Major Change.
4. Uses Not Listed. In the event that a use is proposed that is not listed in the table, the appropriate designee as defined herein shall determine if the use is the same or similar to a use listed in the table. If it is, the use shall be treated in the same manner as the “similar” use. If not, the use is prohibited.

Table 01: Permitted Land Uses			
Permitted Land Use	Phase 2	Phase 3	Phase 4
Retail Uses			
General retail	P	P	P
Wholesale	X	X	X
Grocery store	X	X	X
Alcoholic Beverage Retailer	X	X	X
Motor Vehicle Uses			
Gasoline service/sales	X	X	X
Eating/Drinking Uses			
Coffee/tea shop	P	P	P
Fast casual restaurant	P	P	P
Sit-down restaurant ^[1]	P	P	P
Tavern/brew pub ^[1]	P	P	P
Outdoor dining	P	P	P
Entertainment Uses			
Theater or cinema	X	P	p ^[2]
Entertainment, recreation, or amusement facility	X	P	X
Service Uses			
Athletic, health, or fitness facility	X	P	p ^[2]
Bank, no drive in	P	P	P
General service	P	P	P
Temporary and Permanent Dwelling Uses			
Hotel ^[3]	C	P	P
Multifamily dwelling ^[3]	X	X	C

[1] Shall not derive more than 45 percent of gross sales from the sale of wine, beer, or other alcoholic beverages.

[2] Shall be located more than 200 feet from every boundary of Phase 1.

[3] Street activating uses such as retail, leasing offices, club rooms, fitness rooms, lobbies, and the like are encouraged on the first level.

PERFORMANCE STANDARDS

Uses in The Boulevard Place Planned Development shall be prohibited from activities which may produce or cause any of the following:

- Any noise or sound that is objectionable due to intermittence, beat, frequency, shrillness, or loudness;
- Any obnoxious odor;
- Any excessive quantity of dust, dirt, or fly ash; provided however, this prohibition shall preclude the sale of soils, fertilizers, or other garden materials or building materials in containers of incident to the operation of a wholesale, home improvement, or general merchandise store operated by a national or regional chain;
- Any fire, explosion, or other damaging or dangerous hazard, including the storage, display, or sale of explosives or fireworks, but the foregoing shall not prohibit the operation of a gasoline service/sales use as permitted herein or a propane sales facility as permitted herein and in accordance with applicable law or the sale of fireworks on a temporary basis in connection with civic holidays conducted within the confines of a building containing at least 25,000 square feet of floor area and operated by a national chain; or
- Any dumping of garbage or refuse, other than in enclosed receptacles intended for such purpose.

SITE DEVELOPMENT STANDARDS

Signs

The provisions of this section of the Design Guidelines shall govern the display, construction, erection, alteration, use, location, repair, and maintenance of all signs, together with their appurtenant and auxiliary devices in respect to structural and fire safety in The Boulevard Place Planned Development.

1. Sign Measurement.
 - a. Area to be Included. The supporting structure or bracing of a sign shall be omitted in measuring the area of the sign unless such structure or bracing is made part of the message or face of the sign. Where a sign has more than 1 display face, the area of the sign shall be measured by the largest if the display faces.
 - b. Area of Signs. The area of signs shall be measured by computing the area of the smallest regular geometric figure that can encompass all words, letters, figures, emblems, and other elements of sign copy.
 - c. Multiple Users. Where more than 1 user occupies a building, the owner of the building shall be responsible for allocating permitted signage among such users.

Figure 02

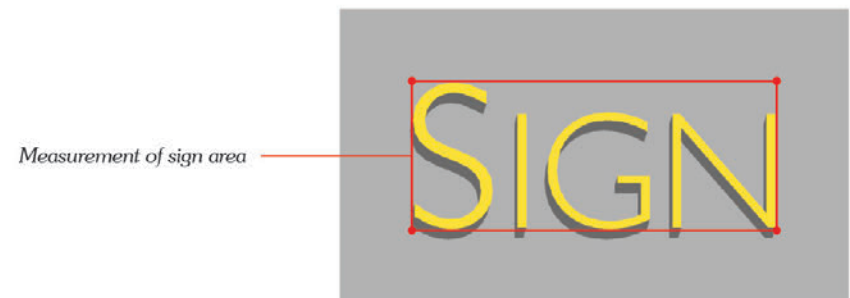

2. Sign Size. The maximum size of aggregate sign(s), regardless of sign type, shall not be greater than 1 square foot of sign area per lineal foot of building frontage.

3. Permitted Signs. The following sign types shall be permitted in The Boulevard Place Planned Development.

a. Shopping Center Signs

i. Highway Electronic Message Center.

1. The existing pole sign located adjacent to I-55 and as identified in the Site Plan shall be permitted.
2. The pole sign shall be converted to include a panel identifying Boulevard Place, which signage panel shall be not larger than 256 square feet per side.
3. The pole may also be converted to include a electronic message center, which electronic message center shall be not larger than 334 square feet per side.
4. A landscape planting area is required at the base of highway electronic message center. The landscape area shall be at least equal to the square footage of each side of the sign in question and shall feature landscape materials which are consistent with and complementary to other required landscape.

ii. Multi-Tenant Shopping Center Signs

1. 1 multi-tenant shopping center sign shall be permitted for each phase of Boulevard Place.
2. Multi-tenant shopping center signs shall be double-sided signs attached to a permanent foundation or decorative base and not attached or dependent on support from any building, pole, posts, or similar uprights.
3. The building materials of the permanent foundation or decorative base of a multi-tenant shopping center sign should be consistent with the building materials used in the phase for which the sign relates.
4. The shopping center sign shall be not taller than twenty feet in height nor have a sign area greater than 50 square feet.

5. Multi-tenant shopping center signs shall only be comprised of individually affixed copy or an electronic message board. Flat or box signs shall be prohibited. The shopping center sign shall be located not less than ten feet from any street frontage, public or private, or any drive aisle.

6. To protect visibility of automotive traffic, cyclists, riders, and pedestrians, no substantial impediment to visibility shall be created or maintained at the intersection of any street and parking drive aisle within the triangular area created by measuring 46 feet along the street and parking drive aisle from the intersection of the street and parking drive aisle and a line connecting those points.

7. A landscape planting area is required at the base of all multi-tenant shopping center signs. The landscape area shall be at least equal to the square footage of each side of the sign in question and shall feature landscape materials which are consistent with and complementary to other required landscape.

Figure 03

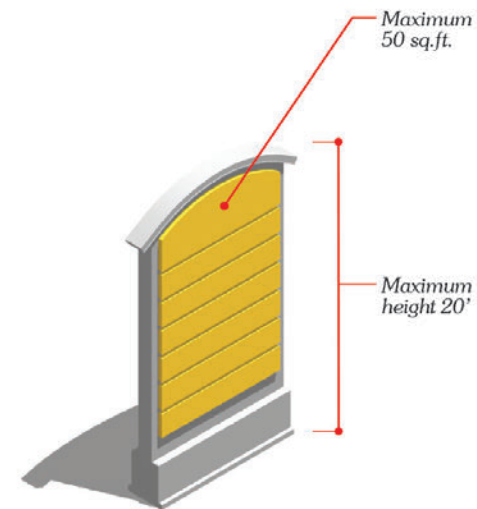

- b. Wall Signs. The installation of a wall sign requires a sign permit issued by the appropriate designee as defined herein.
 - i. Wall signs shall be permitted on any facade with street frontage (public or private) and facade adjacent to an off-street parking area where customer access is also available.
 - ii. Wall signs shall not exceed a maximum area of 1.5 square feet for each linear foot of each facade on which a sign is permitted. On multi-story buildings, wall signs shall be permitted for both first and second story tenants with each floor being allotted a maximum sign area of 1.5 square feet for each linear foot of facade on which a sign is permitted.
 - iii. No wall sign shall protrude above the highest roof line or above the top of the parapet wall.
 - iv. No wall sign shall horizontally project more than 12 inches from the wall of the building or structure to which it is attached.
 - v. Only 1 wall sign per building frontage of the building or unit of a building shall be permitted.
 - vi. On multiple-tenant buildings with multiple wall signs, all signs shall be of the same style, proportions, base colors, and constructed of the same materials.
 - vii. Wall signs shall only be comprised of individually affixed copy. Flat or box signs shall be prohibited.
 - viii. Wall signs may be illuminated through external sources. Internal illumination shall be prohibited.

- ix. No wall sign shall cover any architectural features (architectural features shall include, but not be limited to: pediment, cornice, belt course, pier, windows, pilaster, roof, decorative stone or tile inlay, kick plate/bulkhead, raised or colored brick pattern, and corbel) of the building to which it is affixed.
- x. No wall sign shall be affixed to HVAC screening, elevator overrun, or other features protruding from the roof of the structure, with the exception of building parapets which have been designed and integrated into the architecture of the building and which are in line with and not set back from the perimeter facade of the building.
- xi. Standalone or attached outlet buildings may display an additional wall sign towards a main parking area of the development and not oriented towards a street.

Figure 04

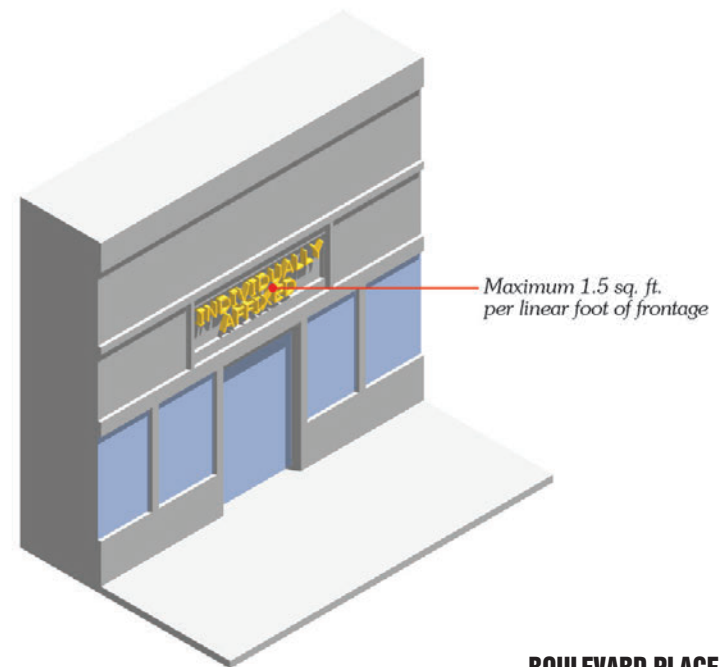

- c. Monument Signs. The installation of a monument sign requires a sign permit issued by the appropriate designee as defined herein.
 - i. The maximum size of a monument sign shall be based on building frontage per Table 02.

Table 02: Permitted Monument Sign Allowance	
Building Frontage	Maximum Sign Area per Face
≤ 50 Feet	25 square feet
> 50 feet	25 square feet plus one additional square foot of sign area per each two feet, or major fraction thereof, of building frontage beyond 50 feet
Maximum	50 square feet

- ii. The maximum height of any monument sign shall be no greater than 8 feet above the center line datum elevation of the street immediately adjacent to the sign location.
- iii. Each building, including multi-tenant buildings may not have more than 1 monument sign, with a maximum of 2 display surfaces. However, any building, including multitenant buildings, which front on more than 1 roadway for an excess of 250 feet may display a secondary monument sign, the size of which shall be equal to or less than the primary monument sign.
- iv. To protect visibility of automotive traffic, cyclists, riders, and pedestrians, no substantial impediment to visibility shall be created or maintained at the intersection of any street and parking drive aisle within the triangular area created by measuring 46 feet along the street and parking drive aisle from the intersection of the street and parking drive aisle and a line connecting those points.
- v. Monument signs shall only be comprised of individually affixed copy or an electronic message board. Flat or box signs shall be prohibited.

- vi. Monument signs featuring individually affixed copy may be illuminated through external sources. Internal illumination of individually affixed copy shall be prohibited.
- vii. No part of any monument sign may be closer than 5 feet from any street frontage, public or private, and any drive aisle, right-of-way or build-to-line.
- viii. No monument sign shall be located within 8 feet of any electrical power line, service drops, line conductors, or in any location where the appropriate designee, as defined herein, finds a reasonable danger that any electric power line would come in contact with the sign.

Figure 05

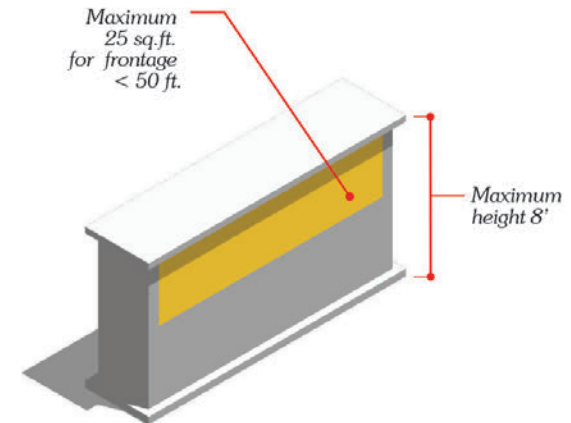

4. Window Signs. Window signs may cover a maximum of 20 percent of the window on which the sign shall be located. The installation of a window sign does not require a sign permit.

Figure 06

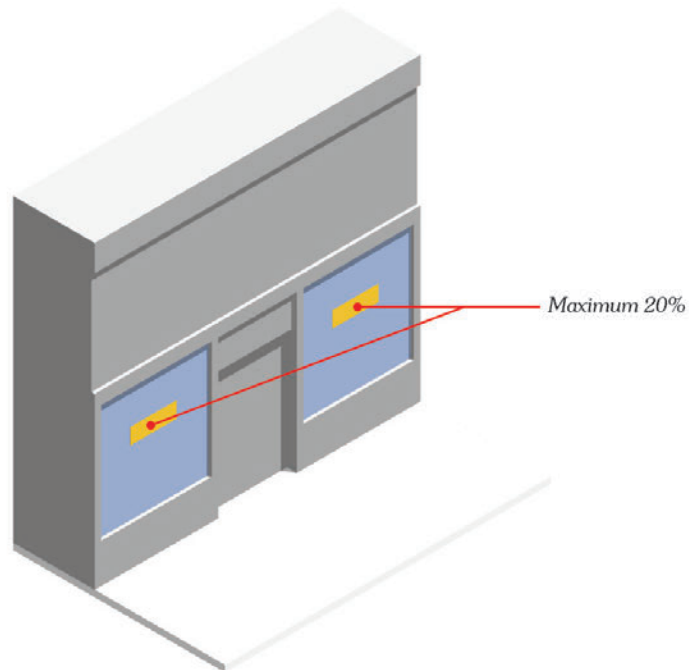

5. Temporary Signs. The display of a temporary sign requires a temporary sign permit issued by the appropriate designee as defined herein.
 - a. The maximum size of a temporary sign shall not be greater than 6 square feet.
 - b. The maximum height of a temporary sign shall be no greater than 3 feet above the center line datum elevation of the street immediately adjacent to the sign location.
 - c. No part of any temporary sign may be closer than 5 feet from any street right of way or property line.
 - d. To protect visibility of automotive traffic, cyclists, riders, and pedestrians, no substantial impediment to visibility shall be created or maintained at the intersection of any street and parking drive aisle within the triangular area created by measuring 46 feet along the street and parking drive aisle from the intersection of the street and parking drive aisle and a line connecting those points.
 - e. A maximum of 2 temporary signs shall be displayed concurrently.
 - f. A temporary sign shall be displayed for a period not to exceed 60 days per calendar year. The appropriate designee as define herein may permit extensions to this time limit.
 - g. No temporary sign, nor any portion thereof, shall be affixed to any building, sign, or structure.
 - h. No temporary sign shall be located within 2 feet of any electrical power line, service drop, or line conductor.
 - i. Temporary signs shall be constructed of durable, all weather material.

Figure 07

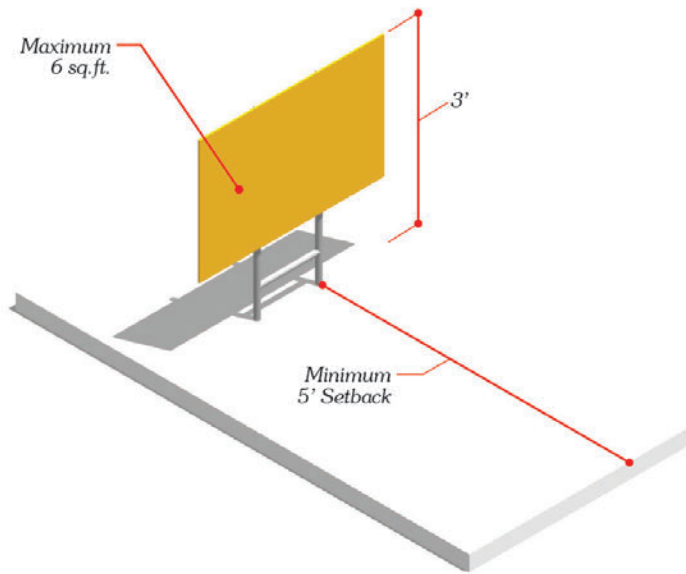

6. On-Site Traffic Directional Sign. Onsite traffic directional signs are permitted as necessary to assist in the movement of vehicular traffic on a property for the purpose of the safety of both pedestrian and vehicular traffic.
 - a. The maximum size of any onsite traffic directional sign shall not be greater than 3 square feet.
 - b. The maximum height of any onsite traffic directional sign shall not be greater than 3 feet.
 - c. No part of any onsite traffic directional sign may be closer than 25 feet from any street right-of-way or property line.
 - d. No part of any onsite traffic directional sign may be located within any required landscape areas.
 - e. On-site traffic directional signs shall be decorative, double-sided engineering grade reflective aluminum or similar material, as shown in Exhibit 01.

Figure 08

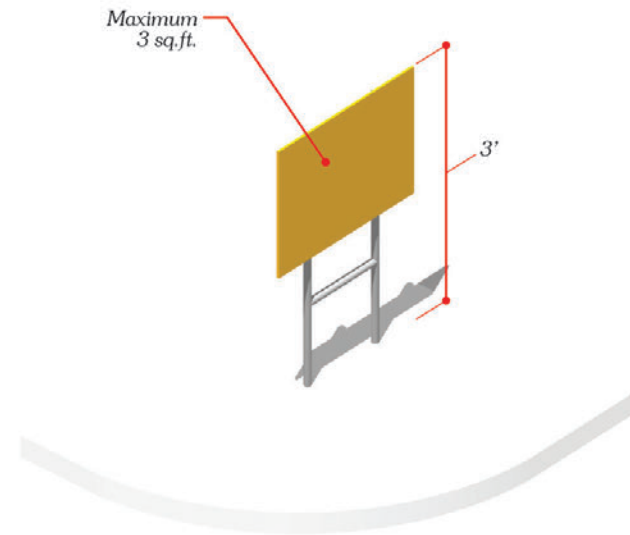

Parking and Loading

The provisions of this section of the Design Guidelines are intended to provide accessible, attractive, secure, and well maintained off-street parking and loading areas with the appropriate number of spaces in proportion to the needs of the proposed use, increase public safety by reducing congestion of roadways and circulation areas, and to encourage The Boulevard Place Planned Development patrons to park once and walk between developments in the site. Required parking shall not be calculated on a lot-by-lot basis, but shall be calculated based on each phase. To this end, a use located in the City of Joliet may rely on parking located in the Village of Plainfield, provided that said parking is located in the same phase of Boulevard Place. Parking may be constructed in sub phases, provided that sufficient access is provided to the sub phase and the proposed parking supply meets the applicable minimum requirements for the uses to be established in said sub phase. Parking shall be a permitted principle use of a lot in Boulevard Place.

1. **Parking Spaces Required.** The total number of parking and loading spaces shall be based upon the sum of the separate requirements for each proposed use of the development phase, except as otherwise provided for in this Section.
2. **Amount of Parking Required.** The minimum number of parking spaces to be provided for the designated uses shall be as follows in Table 03.

Table 03: Parking Requirements

Land Use	Minimum Parking Requirement
Retail Uses	
General retail	1/250 GFA
Multi-tenant retail (in excess of 120,000 square feet)	1/250 GFA
Wholesale	1/800 GFA
Motor Vehicle Uses	
Gasoline service/sales	1/Gas Pump
Eating/Drinking Uses	
Coffee/tea shop	1/250 GFA
Fast casual restaurant	1/250 GFA
Sit-down restaurant	1/250 GFA
Tavern/brew pub	1/250 GFA
Entertainment Uses	
Theater or cinema	1/4 Seats
Entertainment, recreation, or amusement facility	1/250 GFA
Service Uses	
Athletic, health, or fitness facility	1/250 GFA
Bank, no drive in	1/300 GFA
General service	1/300 GFA
Temporary and Permanent Dwelling Uses	
Hotel	1/room and 1/250 GFA of conference or restaurant area
Multifamily dwelling	2.0/dwelling unit

3. Design Standards. Each required off-street parking space shall conform to the standards detailed in Table 04.
4. Surfacing. All off-street parking areas shall be improved with a hard-surfaced, all weather, dustless material as approved by the appropriate designee as defined herein.
5. Striping. All off-street parking areas shall delineate parking spaces with paint or other permanent materials, which shall be maintained in a clearly visible condition. Americans with Disabilities Act compliant parking spaces shall be identified with the appropriate sign and shall be visible at all times of the year, regardless of snow cover, plant growth, or similar conditions.
6. Curbing. Curbing shall be provided along the perimeter of parking areas, internal walkways, and landscape islands to prevent vehicles from damaging or encroaching upon pedestrian spaces or landscaped areas.
7. Drainage and Grading. Where a parking area will be used to detain stormwater runoff, the depth of water shall not exceed 6 inches.
8. Lighting. Adequate lighting shall be provided for parking areas. Poles on which lights are mounted shall not exceed 20 feet in height. Illumination shall be arranged to deflect light away from adjacent properties and streets. Full cutoff luminaries with angles of not more than 90 degrees shall be utilized. Flat lenses are required for all lighting fixtures. Illumination shall not exceed 0.5 foot-candles at the property line.
9. Loading Spaces. Loading spaces shall be provided in compliance with the applicable municipal code, provided that no designated loading spaces shall be required for a building comprising less than 18,000 square feet.

Table 04: Parking Design Standards					
Parking Angle	Single Loaded Module Width (A)	Double Loaded Module Width (B)	Stall Width (C)	Stall Length (D)	Aisle Width (E)
45°	32'	51'	9'	18'	12'
90°	42'	60'	9'	18'	24'

Figure 09

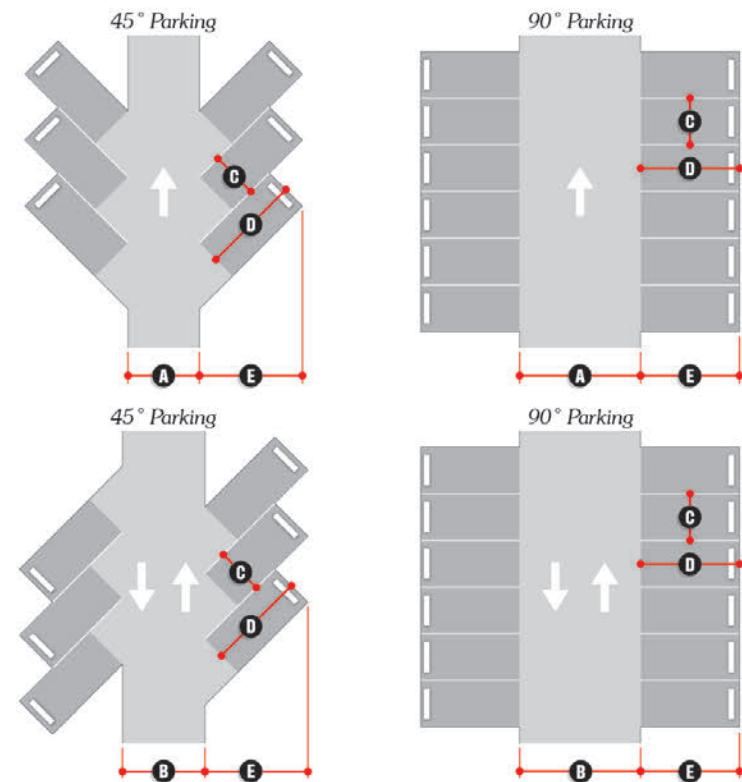

Landscape

Landscape required by this Section shall mean living plants in a combination of trees, shrubs, and/or ground cover. Unless otherwise stated in this ordinance, all size specifications for plant materials shall be based upon the time of planting. When caliper is specified for tree planting, the caliper of the tree trunk shall be measured at 12 inches above the ground level. Any plant materials used to meet the requirements of this Section shall not include any plant material determined by the State of Illinois as an invasive species. The use of native landscape materials is encouraged.

1. Planting Types.

- a. Canopy trees: A self-supporting woody, deciduous plant having not less than a 2.5 inches caliper and reaches a mature height of not less than 20 feet and a mature spread of not less than 15 feet.
- b. Ornamental trees: A self-supporting woody, deciduous plant having not less than a 1.5 inches caliper and normally attains a mature height of at least 15 feet and usually has 1 main stem or trunk and many branches. Several species may appear to have several stems or trunks.
- c. Evergreen trees: A tree having foliage that persists and remains green throughout the year and having a height of not less than 6 feet at installation and maturing to a height of not less than 20 feet.
- d. Shrub: A woody perennial plant (deciduous or evergreen) of low to medium height characterized by multiple stems and branches continuous from its base and having a height of not less than 2 feet and normally maturing to a height of not more than 5 feet.
- e. Ground cover: Plants, other than turf grass, normally reaching an average maximum height of not more than 18 inches at maturity.

2. Required Landscape Elements. Figure 11 illustrates the location of required landscape areas.

Figure 10

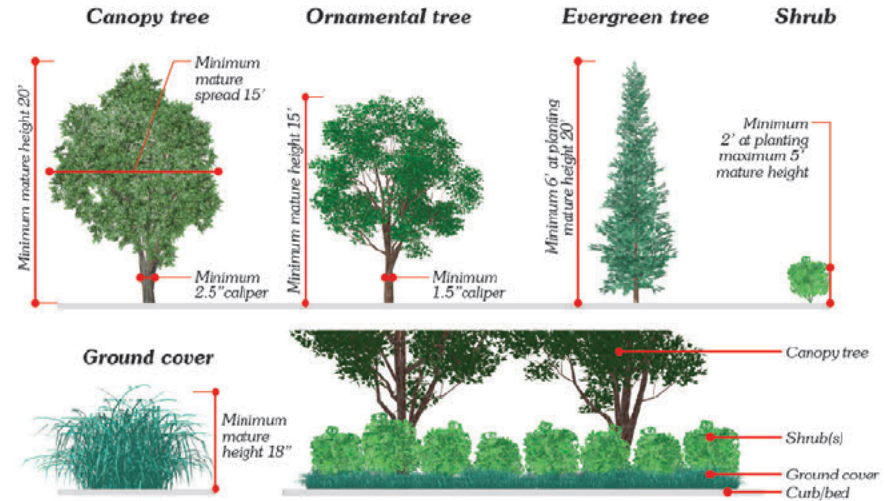

Figure 11



3. Building Foundation Area.

- a. All buildings are required to maintain a building foundation area along primary and secondary façades with a minimum depth of 5 feet. No building foundation area landscape shall be required on any secondary façade of a building designated as a service area. However, the use of landscape elements such as planters is encouraged to minimize the visual impact of any “back-of-house” type activities.
- b. Building foundation plantings shall be designed to supplement and complement other required landscape elements, to frame important views, and visually soften long expanses of wall. Building foundation planting shall respond to the windows and materials of the building.
- c. Foundation plantings shall be installed across a minimum of 50 percent of the length of the primary façade and a minimum of 60 percent of the length of the secondary façade, except where walkways, entrances, outdoor patios or other similar amenity spaces are located.

Figure 12

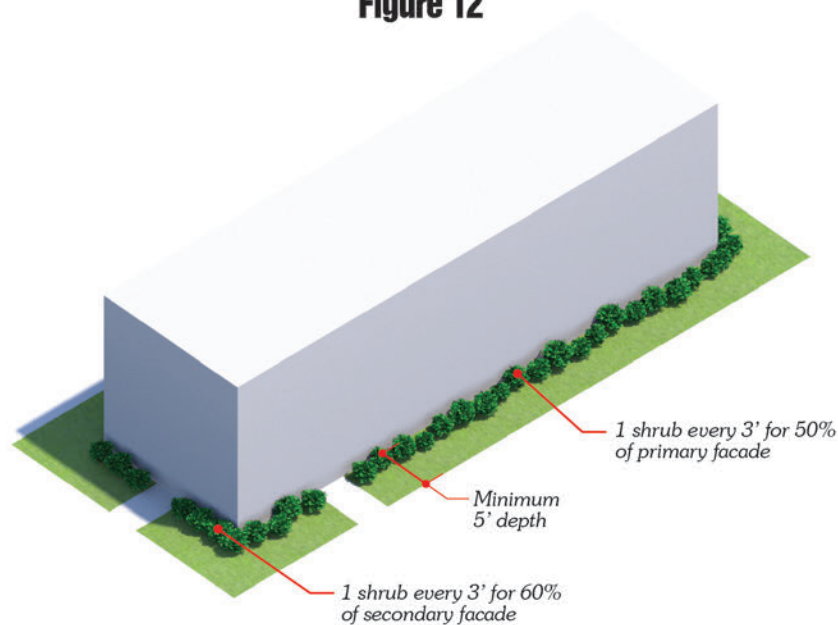

4. Parking Lot Interior Area.

- a. All parking lots shall include landscaping and trees located within the parking area as required by this Section. Landscape elements required by this Section shall be in addition to landscape elements required under other sections of the Design Guidelines. It is the objective of this Section to provide shade within parking areas, break up large expanses of parking lot pavement, provide a safe pedestrian environment, and assist in the absorption of stormwater runoff.
- b. 1 parking lot island shall be provided between every 20 parking spaces. Parking lot island locations may be varied based on the specific site requirements or design scheme.
- c. Double rows of parking shall provide parking lot islands that are the same dimension as the double row.
- d. A minimum of 1 canopy tree shall be provided for every parking lot island. If the island extends the width of a double row, then 2 canopy trees shall be provided.
- e. The use of ornamental trees, evergreen trees, shrubs, and other plant materials are encouraged to supplement the canopy tree plantings but shall not create visibility concerns for automobiles and pedestrians.
- f. Parking lot islands shall be at least 144 square feet in area and at least 6 inches above the surface of the parking lot and protected with concrete curbing, except where designed specifically for the absorption of stormwater.
- g. Parking lot islands shall be properly drained and irrigated as appropriate to the site conditions to ensure survivability.

Figure 13

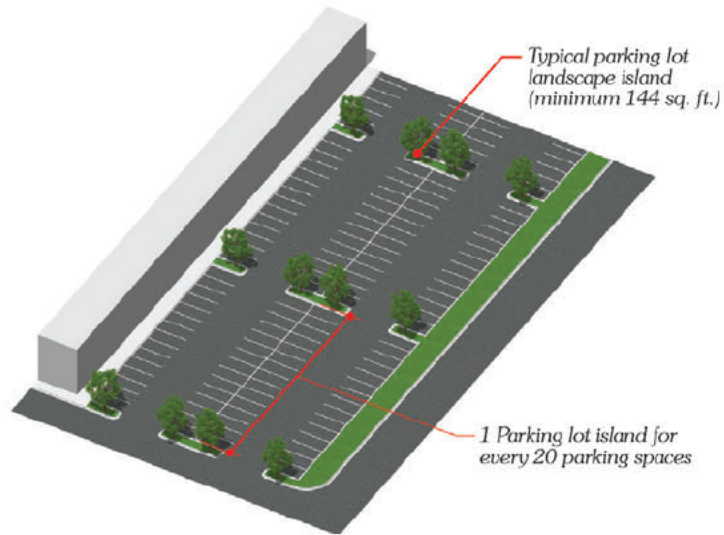
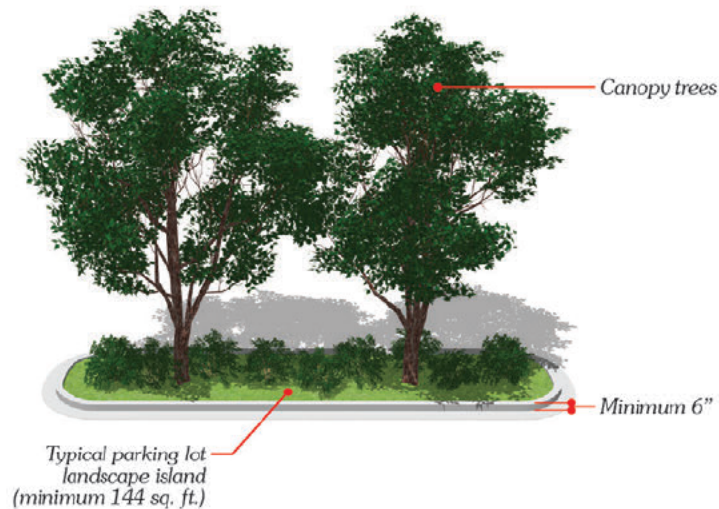

Figure 14



5. Parking Lot Perimeter Area.

- a. Parking lot design shall provide for perimeter landscape areas around the perimeter of each phase of Boulevard Place. Perimeter landscape areas shall not be required internal to a phase or between individual lots in each phase.
- b. Perimeter landscaping shall be a minimum depth of 10 feet as measured from the back of curb, to accommodate vehicle bumper overhang and ensure planting areas that are adequate in size.
- c. The landscape treatment shall run the full length of the parking lot and shall be located between the property line and the edge of the parking lot. All perimeter parking lot areas shall be protected with raised concrete curbs.
- d. Perimeter parking lot landscaping shall consist of a minimum of 2 evergreen or ornamental trees, 1 canopy tree, 20 shrubs, and 40 ground cover plantings, every 100 lineal feet.

6. Tree Preservation. The preservation of significant and high quality trees was considered during site plan design. In lieu of tree preservation not possible through site planning, the natural areas surrounding Mink Creek and Lilly Creek will be enhanced and restored.

Screening

1. Trash and Recycling Receptacles

- a. Trash and recycling receptacles shall be screened using the same materials and elevations as used on the main structure, on 3 sides to a height that screens the containers, having a minimum height of 6 feet, and a maximum height of 8 feet.
- b. The use of materials that are not the same as the materials and elevations of the main structure shall not be used to meet this requirement.
- c. Enclosure openings directly visible from a public right-of-way shall have a solid material gate. For larger enclosure areas, a separate gate access is encouraged.
- d. Enclosures shall be of an adequate size to accommodate expected containers. It is encouraged to design the enclosure area to be expandable to accommodate future additional containers.
- e. Trash enclosures shall not be located within a required street front or street side setbacks or occupy area used for required parking spaces.

2. Ground Mounted Mechanical Units

- a. All ground-mounted mechanical units, including but not limited to air-conditioning condensers, heat pumps, ventilation units, computer cooling equipment, etc., and any related utility structures and equipment, that are visible from any public space in The Boulevard Place Planned Development shall be screened from public view. The screening may consist of fencing, landscaping or some combination thereof. The screening shall be designed and established so that the area or element being screened is no more than 20 percent visible through the screen.

3. Roof Mounted Mechanical Units

- a. All roof-mounted mechanical units shall be screened from any public space in The Boulevard Place Planned Development using an opaque screening material compatible with the architecture of the building or architecturally designed screening such as a parapet wall. The screening of the roof-mounted units shall be designed to blend with the building and roof materials.

Figure 15

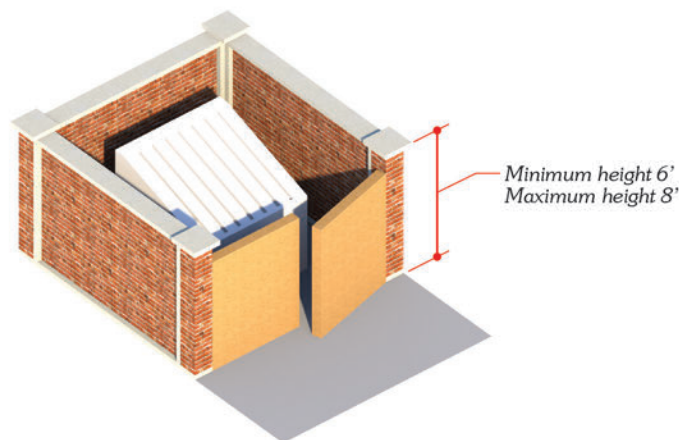

BUILDING LAYOUT AND DIMENSIONAL STANDARDS

Building Façades

1. Primary Façade. The primary façade of the building shall include that façade(s) which contains the primary entrance to the building.
2. Secondary Façade. The secondary façade of the building shall include a façade(s) which is not a primary façade, and fronts Boulevard Place, or any parking area, parking circulation drive, or secondary façade of any other building theretofore constructed.
3. Tertiary Façade. The tertiary façade of the building shall include that façade(s) which is not a primary or secondary façade and fronts the tertiary façade of any other building theretofore constructed.

Figure 16

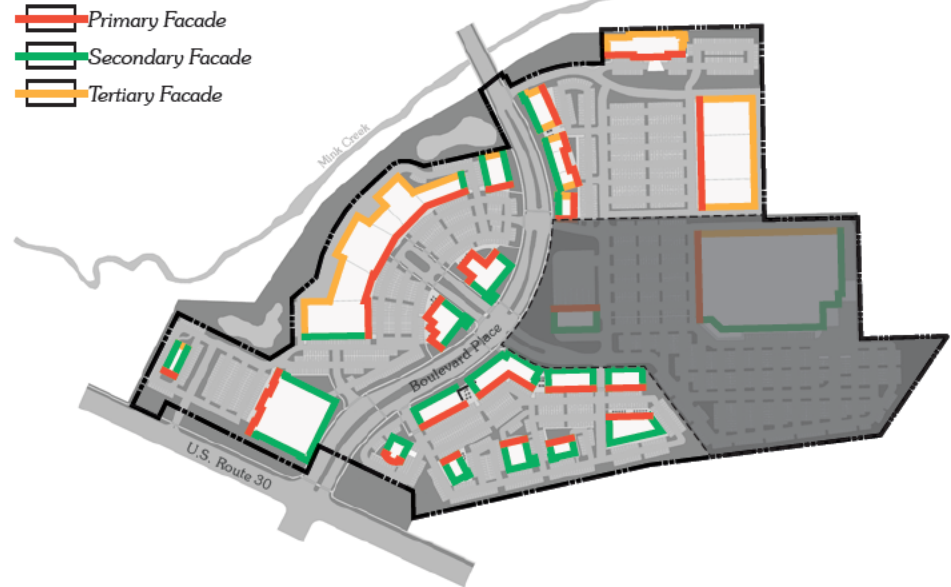

Building Height

The following building heights shall be considered maximums in the applicable phase as indicated in Table 05. Building height shall be measured from the front finished grade to the top of the parapet or eave line of a pitched roof.

Table 05: Building Height			
Development Phase	Building Height Maximum	Building Height Minimum	Stories
Phase 2	20 feet	18 feet	1
Phase 3	40 feet	18 feet	2
Phase 4	60 feet	18 feet	5

Figure 17

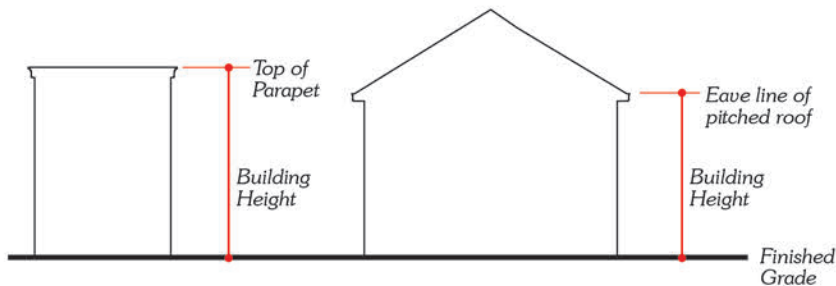

BUILDING DESIGN STANDARDS

These standards are established to ensure that buildings within Boulevard Place are unique yet consistent parts of the overall planned development. Building designs should provide sufficient articulation to create human-scaled architecture, create a sense of place within each development phase, and complement the design of Boulevard Place as a whole. In the case that more than 1 façade designation may be attributed to a single façade, the more stringent requirements shall apply. The following standards shall apply to anchor and outlot buildings.

1. **Roofs.** Roofs shall provide a skyline to add interest in both height and plane changes. Roof slopes and materials shall be consistent with the shopping center standard.
2. **Vista Terminations.** When buildings are situated such that the centerline of a street or open space intersects with said building, the building façade shall be located and designed as a vista termination to visually attract a viewer's attention at the end of a visual axis and designed to terminate a view with an architectural feature such as a tower, corner tower, symmetrical façade centered on a visual axis, an architecturally embellished entrance, or similar architectural devices.
3. **Entrances.** Whenever possible, entrances shall be co-located with vista terminations. All entrances shall be visually defined to emphasize a sense of arrival and place.
4. **Service Areas.** Whenever possible, service areas shall be located on tertiary facades. When a building does not have a tertiary façade, as identified in Figure 17, service areas shall be located on a secondary façade. Service areas located on a secondary façade shall be integrated into the design of the building to minimize visual impact through architectural features and landscape elements.

Primary Façade Design

The primary façade of all buildings should be designed in a manner which fosters a pedestrian environment. Primary façades shall be consistent with the overall shopping center design and create unique and interesting elevations. Primary façades shall be designed to reduce mass and create an interesting visual rhythm and skyline. Primary façades should feature varying material color, texture, and vertical and horizontal plane change through the use of features such as bulkheads, piers, cornices, window hoods, etc.

1. Building Materials. Building materials of primary façades shall be masonry, stone veneer systems, stucco or precast panels with stamped or inlaid brick texture on the first level. EIFS acrylic finishes or quik-brik concrete masonry units may be utilized above the first level. However, in no instance shall the finish of the EIFS acrylic finishes or quik-brik concrete masonry units utilized mimic or match the texture of the masonry, stone veneer systems, stucco, or precast panels with stamped or inlaid brick texture utilized. A maximum of 3 building materials may be used on a primary façade.
 - a. Balance of Building Materials. When 2 or more building materials are used on a façade, the material used on the first level should be visually heavier than the material used above the first level to give a sense of support and grounding. For example, masonry on the first level and EIFS acrylic stucco above.
 - b. Colors. The use of garish, high-intensity, metallic, fluorescent, day glow, or neon colors is prohibited. A list of recommended building materials is included in Exhibit 01.
 - c. Additional Detail. Additional detail such as inlaid tile, soldier courses, trim, planters, and decorative lighting are encouraged.
2. Windows. Windows shall be of clear glass or with a low-emissivity coating. No mirrored or tinted glass shall be permitted. Window size should respect the pedestrian scale and be aligned to follow the grade of the sidewalk. The following requirements shall be applicable to the land use categories as indicated:
 - a. Retail Uses.
 - i. Windows should comprise a minimum of 70 percent of the first level of the primary façade of any retail use.
 - ii. The developer should avoid horizontal banding on windows and limit mullions to reduce visual barriers between consumers and merchandise.
 - iii. Any windows in the doorway of a retail use shall not count towards satisfying the minimum window requirement.
 - b. Eating/Drinking Uses.
 - i. Windows should comprise a minimum of 70 percent of the first level of the primary façade of any eating/drinking use.
 - ii. Any windows in the doorway of a eating/drinking use shall not count towards satisfying the minimum window requirement.
 - iii. The developer is encouraged to install sliding, French, or folding doors and windows to create an indoor/outdoor environment.
 - c. Entertainment Uses.
 - i. Windows should comprise a minimum of 30 percent of the first level of the primary façade of any entertainment use.
 - ii. Windows in doorways shall count towards satisfying the minimum requirement.
 - d. Service Uses.
 - i. Windows should comprise a minimum of 50 percent of the first level of the primary façade of any service use.
 - ii. Windows in doorways shall count towards satisfying the minimum requirement.
 - iii. Windows should be evenly spaced and the same size.
 - e. Temporary and Permanent Dwelling Uses.
 - i. Windows shall have a vertical proportion.
 - ii. Windows shall be regularly spaced and the same size, except for accent windows.
3. Façade Articulation. In order to provide for primary façade articulation, primary façades shall step back a maximum of 2 feet and shall step forward a maximum of 1 foot from the build-to-line for a minimum of 40 percent and maximum of 70 percent of the primary façade.

Secondary Façade Design

The secondary façade of all buildings should be designed in a manner which fosters a pedestrian environment. Secondary façades shall be consistent with the overall shopping center design and create unique and interesting elevations. Secondary façades shall be designed to reduce mass and create an interesting visual rhythm and skyline. Secondary façades should feature varying material color, texture, and façade articulation which complements the primary façade and activates the public realm.

1. **Building Materials.** 60 percent of building materials of the secondary façade shall be masonry, stone veneer systems, stucco, or precast panels with stamped or inlaid brick texture. The remaining 40 percent of building materials of the secondary façade may incorporate EIFS acrylic finishes or quik-brik concrete masonry units. In no instance shall the finish of the EIFS acrylic finishes or quik-brik concrete masonry units utilized mimic or match the texture of the masonry, stone veneer systems, stucco, or precast panels with stamped or inlaid brick texture utilized. The type and design of materials utilized on the secondary façade shall complement those utilized on the primary façade.
2. **Windows.** Windows shall not be required but are encouraged on the secondary façade. If windows are installed, no mirrored or tinted glass shall be permitted, and window size and placement shall be complementary to the primary façade.
3. **Façade Articulation.** In order to provide for secondary façade articulation, secondary façades shall step back a maximum of 2 feet and shall step forward a maximum of 1 foot from the build-to-line for a minimum of 30 percent and maximum of 70 percent of the secondary façade. Articulation of the secondary façade shall be complimentary to the articulation of the primary façade.

Tertiary Façade Design

The tertiary façade of all buildings should be designed in a manner which complements the primary and secondary façades and is consistent with the overall shopping center design.

1. **Building Materials.** Building materials of tertiary façades may consist wholly of precast panels with stamped or inlaid brick texture, EIFS acrylic finishes, or quik-brik concrete masonry units, however, a combination of non-natural and natural materials is encouraged. The type and design of materials utilized on the tertiary façade shall complement those utilized on the primary and secondary façades.
2. **Windows.** Windows shall not be required but are encouraged on the tertiary façade. If windows are installed, no mirrored or tinted glass shall be permitted, and window size and placement shall be complementary to the primary and secondary façades.
3. **Open Space Integration.** Developers are encouraged to integrate tertiary façades with required open spaces through the use of murals, side entrances, lighting, and other features which connect buildings with active or passive open space.

OPEN SPACE

1. Definition. Open space shall not include landscape or sidewalk required herein and shall be defined as land or water that is open to the air and used for active or passive recreation, including;
 - a. Lawn;
 - b. Garden;
 - c. Courtyard;
 - d. Square;
 - e. Plaza;
 - f. Outdoor dining;
 - g. Park;
 - h. Linear green;
 - i. Water features;
2. Location. Open spaces should be provided in areas which are easily accessed and viewed by pedestrians. The nature of activities for which open space is programmed should have an active relationship with surrounding buildings.
3. Amenities. Developers are encouraged to activate open spaces to include the creative and flexible use of outdoor furniture, recreational amenities, and/or landscaping. All amenities in open spaces should complement the aesthetics of the building. Open spaces not otherwise activated should be furnished with benches and trash cans, as detailed in Exhibit 01.
4. Outdoor Dining. When outdoor dining areas are immediately adjacent to parking areas or parking circulation areas, there shall be physical barrier to separate them, as detailed in Exhibit 01.

DEFINITIONS

Except where specifically defined herein, all words used carry their customary meanings. For terms not defined herein but defined in the Code of Ordinances of Plainfield or Joliet, the definitions in those ordinances shall apply. In the event that a definition in the Design Guidelines conflicts with a definition in the Code of Ordinances of Plainfield or Joliet, the definitions in the Design Guidelines shall control.

Term	Definition
Appropriate Designee	shall mean the Village of Plainfield Director of Planning or the City of Joliet Director of Community Development depending on the location of the proposed site development.
On-Site Traffic Directional Sign	shall mean a sign which assists in the movement of vehicular traffic on a property for the purpose of the safety of both pedestrian and vehicular traffic.
Planned Site Development	shall mean the development of any phase or any portion of a phase of The Boulevard Place Planned Development.
Primary Façade	shall mean the façade(s) which contains the primary entrance to the building.
Secondary Façade	shall mean the façade(s) which is not a primary façade, and fronts Boulevard Place, or any parking area, parking circulation drive, or secondary façade of any other building theretofore constructed.
Service Area	Shall mean the area that provides for loading, refuse, utilities or other similar “back-of-house” type activities.
Site	shall mean the building and corresponding parking, landscaping, and open space of any development within any phase of The Boulevard Place Planned Development.
Tertiary Façade	shall mean the façade(s) which is not a primary or secondary façade and fronts the tertiary façade of any other building theretofore constructed.

Exhibit 01

Building Materials



Brick: Buff



Brick: Brown



Brick: Red

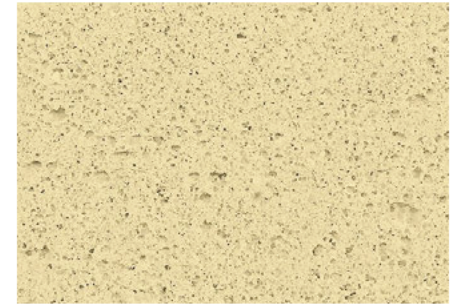

Cast Stone



Simulated Stone Veneer



Metal Roof

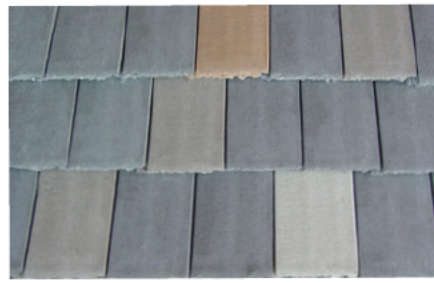

Concrete Tile Roof

EIFS Swatches

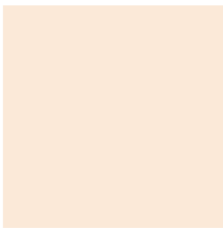

Outdoor Dining Example



Brick & EIFS Examples



Bronze

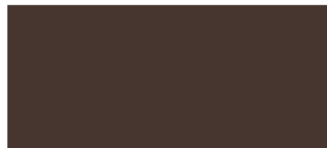

Victor Stanley Bench



Victor Stanley Trash Receptacle

Example On-Site Traffic Directional Sign



Candela Pendant Large Pedestrian Light



McGraw-Edison LED Talon Parking Lot Light



OUT LOTS AND RETAIL SPACE
AVAILABLE
Call Mike Hester 430 573 7112
Call Matt Hester 430 573 7114
CORG

LONGHORN
STEAKHOUSE

LONGHORN
STEAKHOUSE





OUT LOTS AND RETAIL SPACE
AVAILABLE

LONGHORN
STEAKHOUSE

LONGHORN
STEAKHOUSE

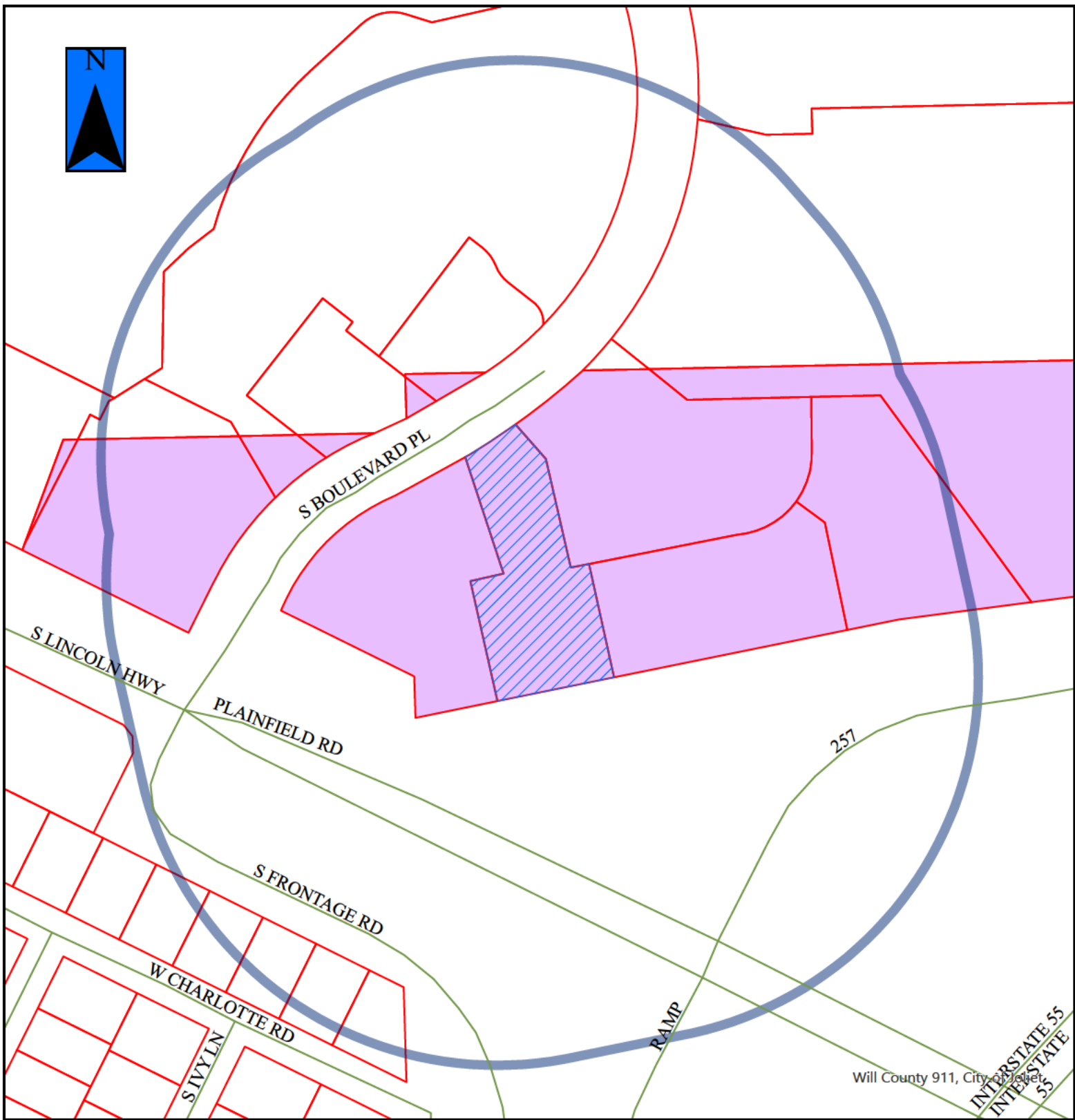

2026-04



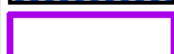

 = Property in Question
 = 600' Public Notification Boundary

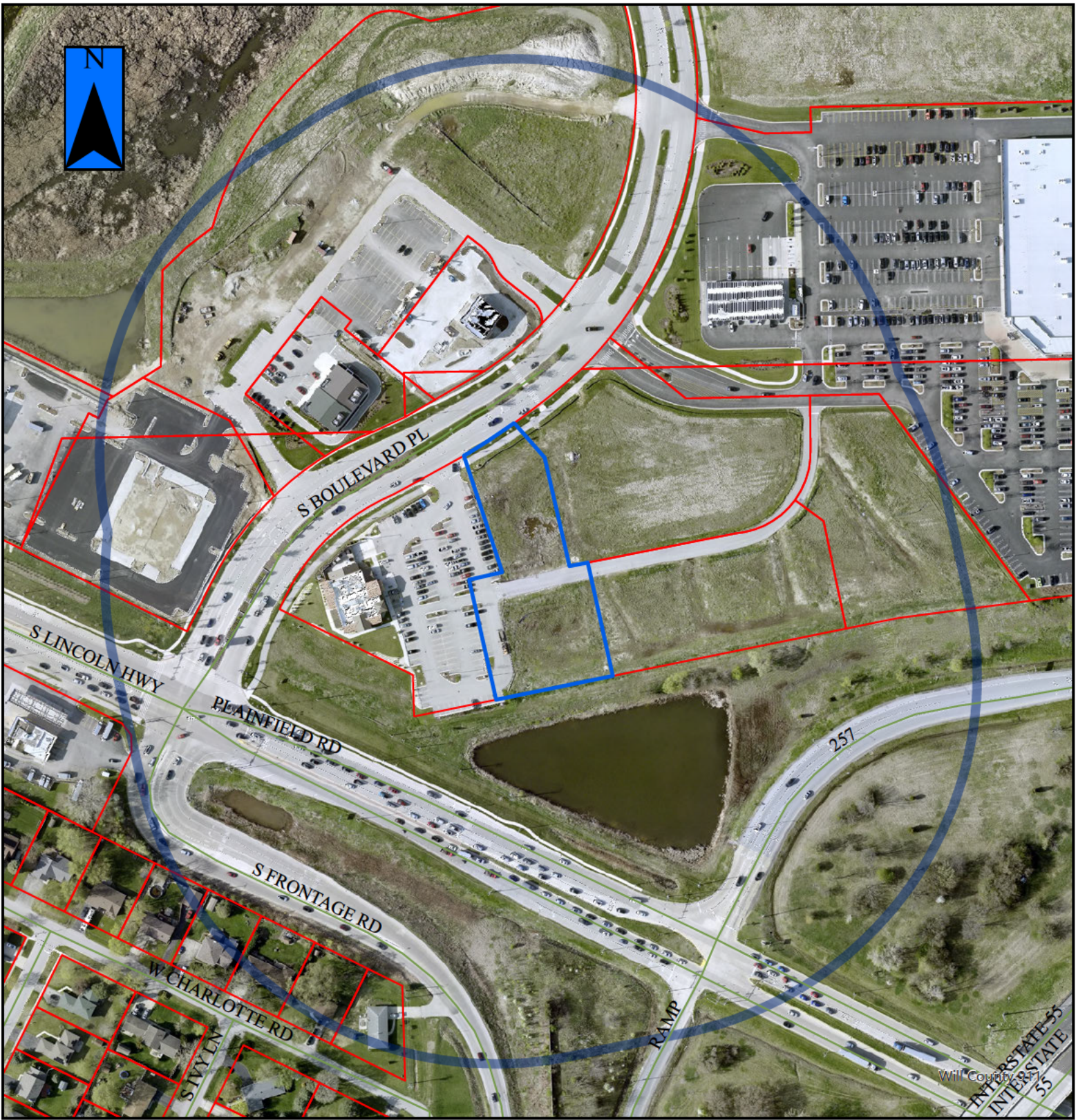
Legend			
	B-1		R-2
	B-2		I-TA
	B-3		I-TB
	I-1		I-TC
	I-2		R-3
	I-T		R-1
			R-1A
			R-1B
			R-2A
			R-3
			R-4
			R-5
			R-B



2026-04a



-  = Property in Question / Propiedad en cuestión
-  = 600' Public Notification Boundary / Límite de notificación pública de 600 ft (180 m)